



Design and Implementation of a Link Level Adaptive Software Radio

Information & Telecommunication
Technology Center

Richard A. Killoy

May 27, 1999





Presentation Overview

- Brief Overview of RDRN
- Motivation - Why build this radio?
- Transceiver System Level Description
- Transmit and Receive Chain
Implementation
- Summary & Future Work



RDRN Overview

- Design High-Speed wireless ATM/IP Comm. Systems with Network and DLL adaptability which are rapidly deployable.
- Sponsored by DARPA's GLO-MO initiative



This years goals:

- Channel Estimation & Link Adaptation
- Software Radios
- Adaptive Networking
- Resource Reservation Styles
- Comparative Performance Evaluation of IP vs. ATM



RDRN System Architecture

Three Overlaid Radio Networks:

- Low-Power Orderwire for signaling
- High Capacity wireless ATM backbone
- Cellular-like Radio Network for ATM access to end users

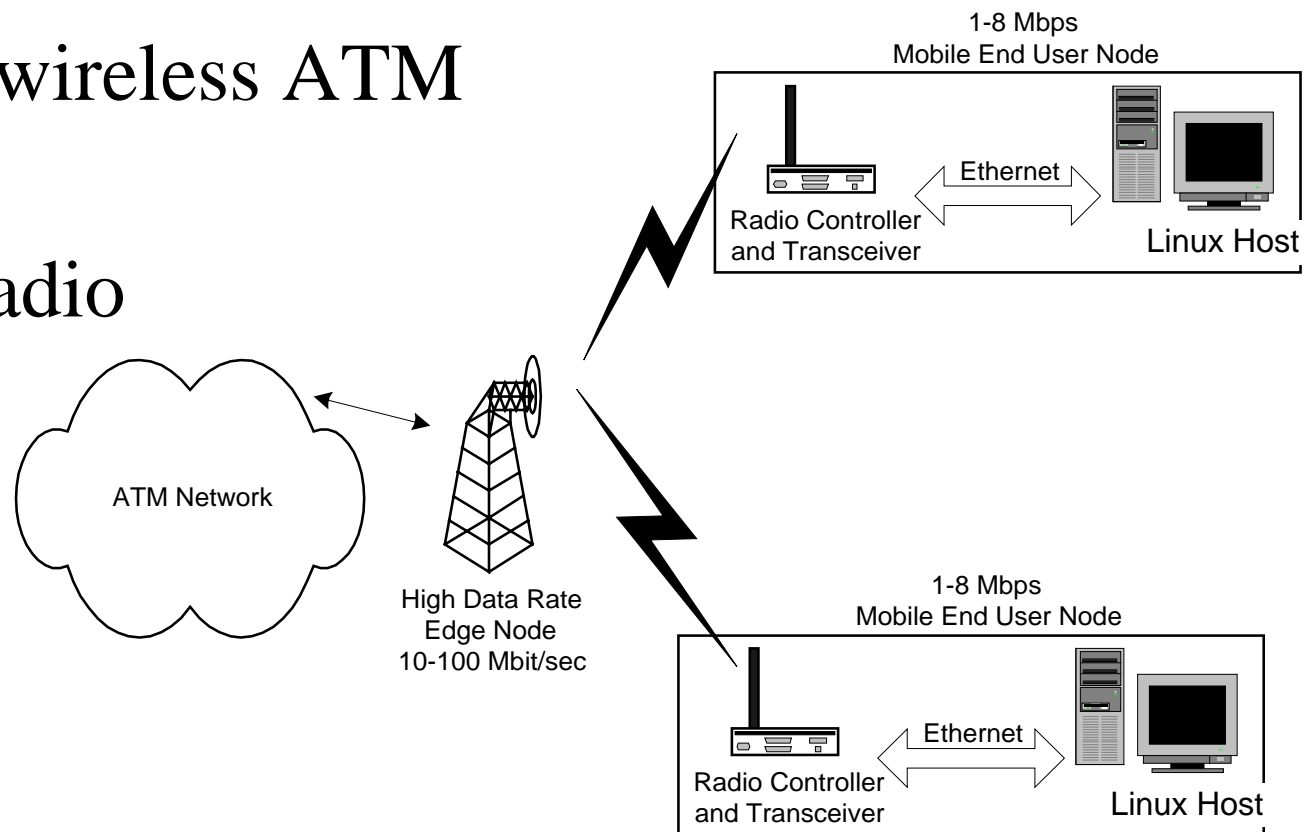



Motivation

Goal	Solution Strategy Employed
Channel Estimation Algorithms	The use of adaptive equalization, functioning as channel estimators.
Link Level Adaptation Algorithms	Software radio allows us the flexibility to change link level parameters.
Radios to Test, Evaluate, and Validate the channel estimation and link-level algorithms	Software radios implementing the use of high-speed ADC and various DSP chips. These chips can be programmed dynamically via a PowerPC processor.



Adaptive Parameter	Allowable Values
<i>RF Section</i>	
Transmit Power Control, TPC	5 dBm to 25 dBm in 2 dB increments
Carrier Frequency	Carrier frequency can be tuned within RF bandwidth in increments of 10 MHz
*RF Front End	Static Design, but supports 5.3 GHz, 2.4 GHz, and 1.2 GHz band.
<i>Physical Layer</i>	
Modulation format	BPSK, QPSK
Data Rate	1, 2, 4 MSPS
<i>Data Link Layer</i>	
FEC	Limited by complexity of combinational logic circuit implemented in Alteras
Multiple Access Scheme	TDMA, FDMA or hybrid combination of both
RF Preamble for TDMA	Limited by length of time slot
HDLC Frame Length	Limited by Ethernet Packet Size, 1.5 kB



Complete System Including Housing

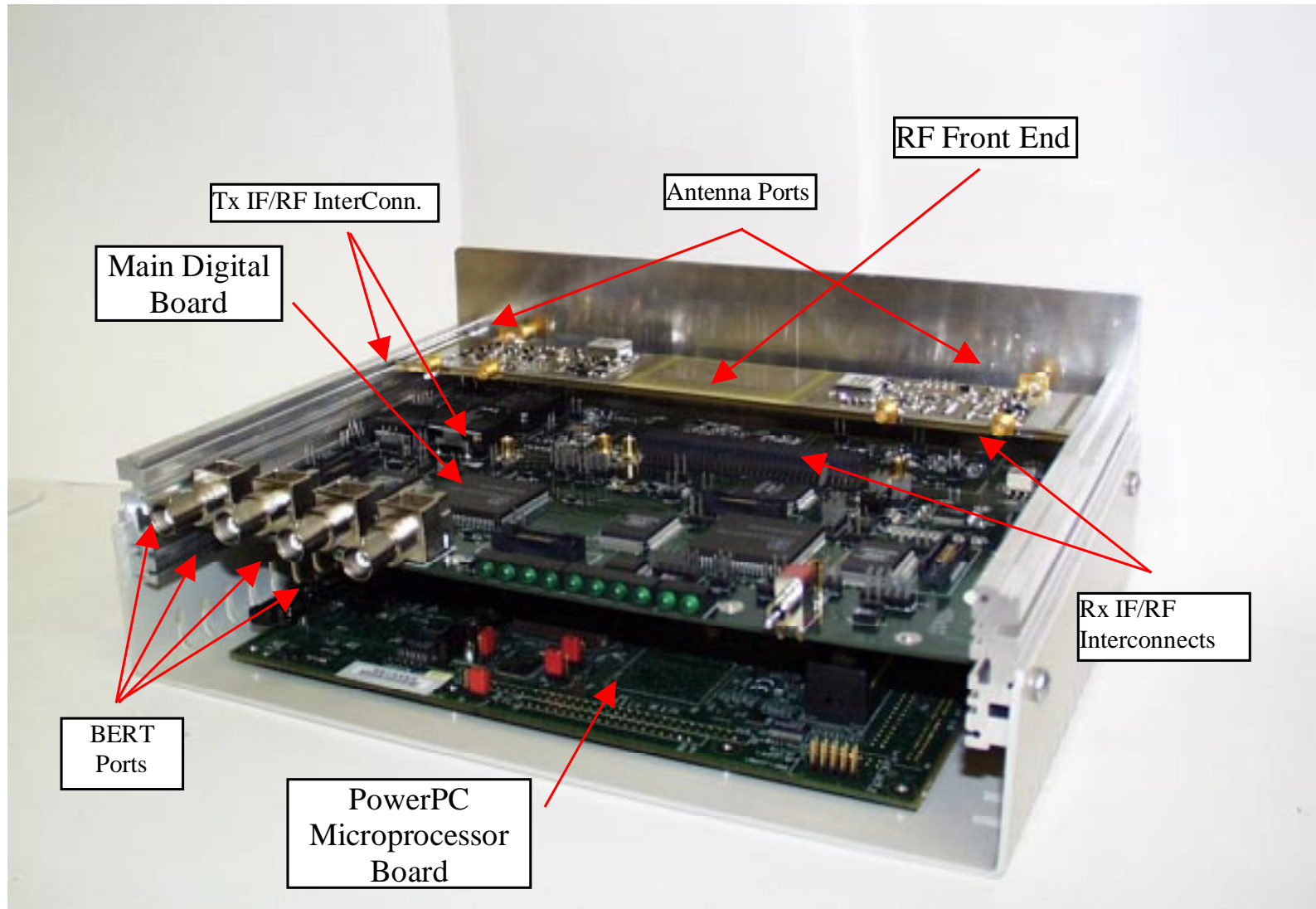



Transmitter Requirements

- Transmit within RF bands at 5.3 GHz, 2.4 GHz, and 1.2 GHz
 - Frequency Agility – ability to select from multiple channels within each RF band
 - Average power output of +30 dBm (1W) from each antenna
 - RF Bandwidth = 100 MHz
 - Channel BW = 10 MHz
 - Selectable QPSK or BPSK modulation
 - Symbol Rates of 1, 2, or 4 Msymbols/sec
 - Multiple Access: FDD with TDMA/FDMA
 - Transmit Power Control (2 dB steps from 5 dBm to 25 dBm)
 - Transmit Power ON/OFF capability (TDMA)
 - TxData received from PowerPC
 - LO Spurious level = -28 dBm
 - LO Phase Noise ≤ -130 dBc/Hz at 50 MHz offset
-



Transmitter System Level Diagram

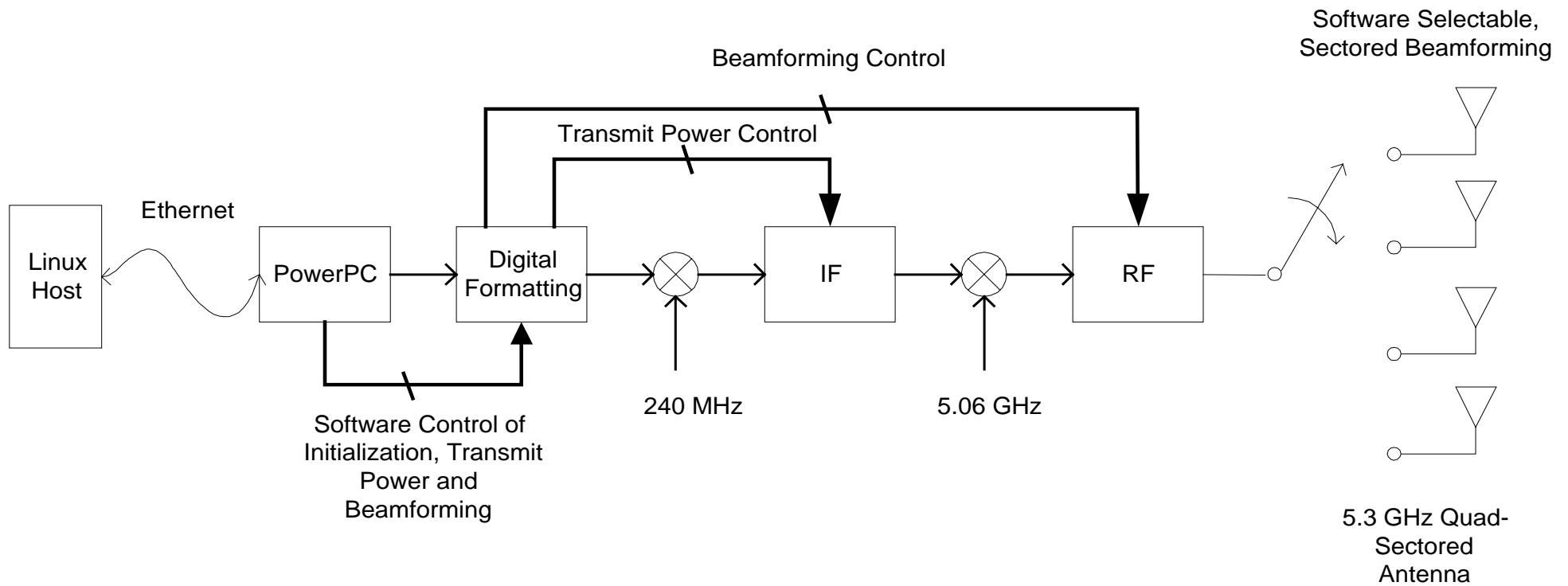



Spectrum Utilization

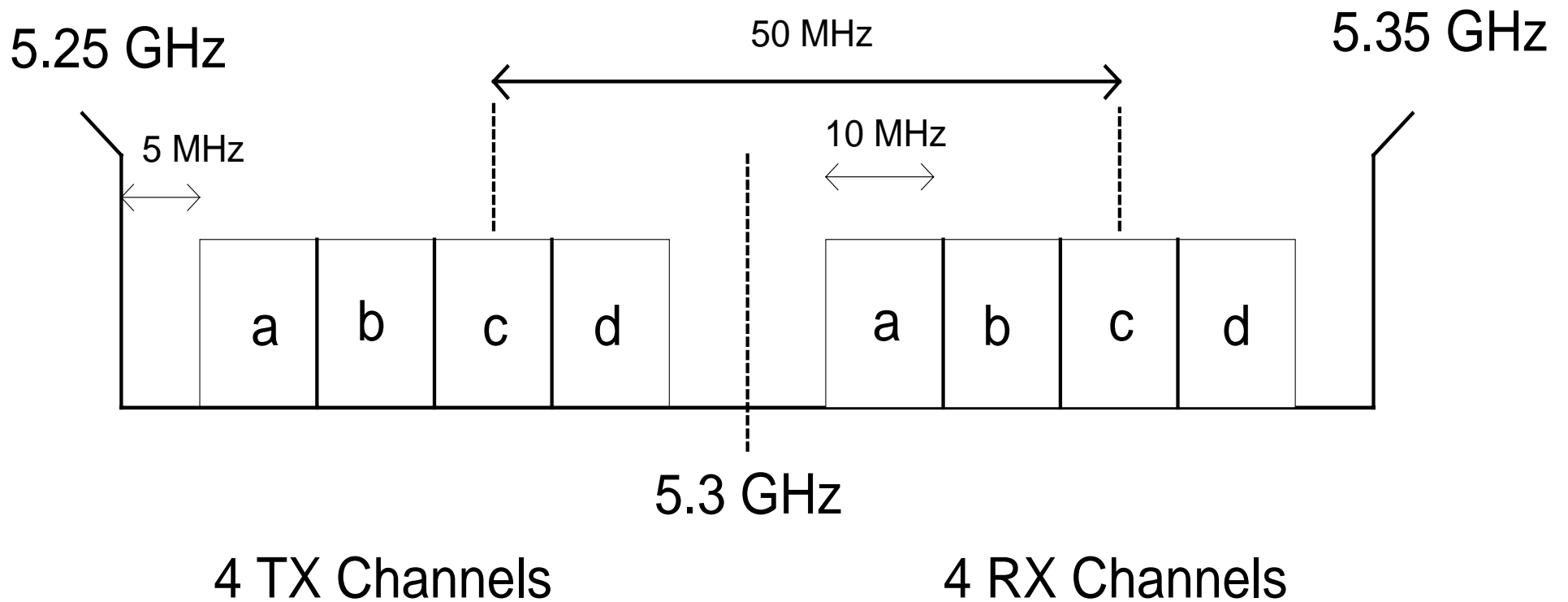

1 Channel = 10 MHz

RF Band = 100 MHz



Receiver Requirements

- Receive within RF bands at 5.3 GHz, 2.4 GHz and 1.2 GHz
 - Frequency Agility – ability to select from four channels within RF band
 - Full Duplex Operation
 - Digital IF Architecture (subsampling)
 - Demodulate QPSK or BPSK modulation
 - Receiver band selectivity = 100 MHz
 - Receiver channel selectivity = 10 MHz
 - Symbol Rates from 1, 2 or 4 MSymbols/sec
 - Dynamically configurable – must be a multidimensional radio with varying software profiles (Software Radio)
 - RxData passed to PowerPC
 - $NF_{\max} \leq 10$ dB
 - Receiver sensitivity = -85 dBm
 - Dynamic Range = 60 dB
-



Receiver System Level Diagram

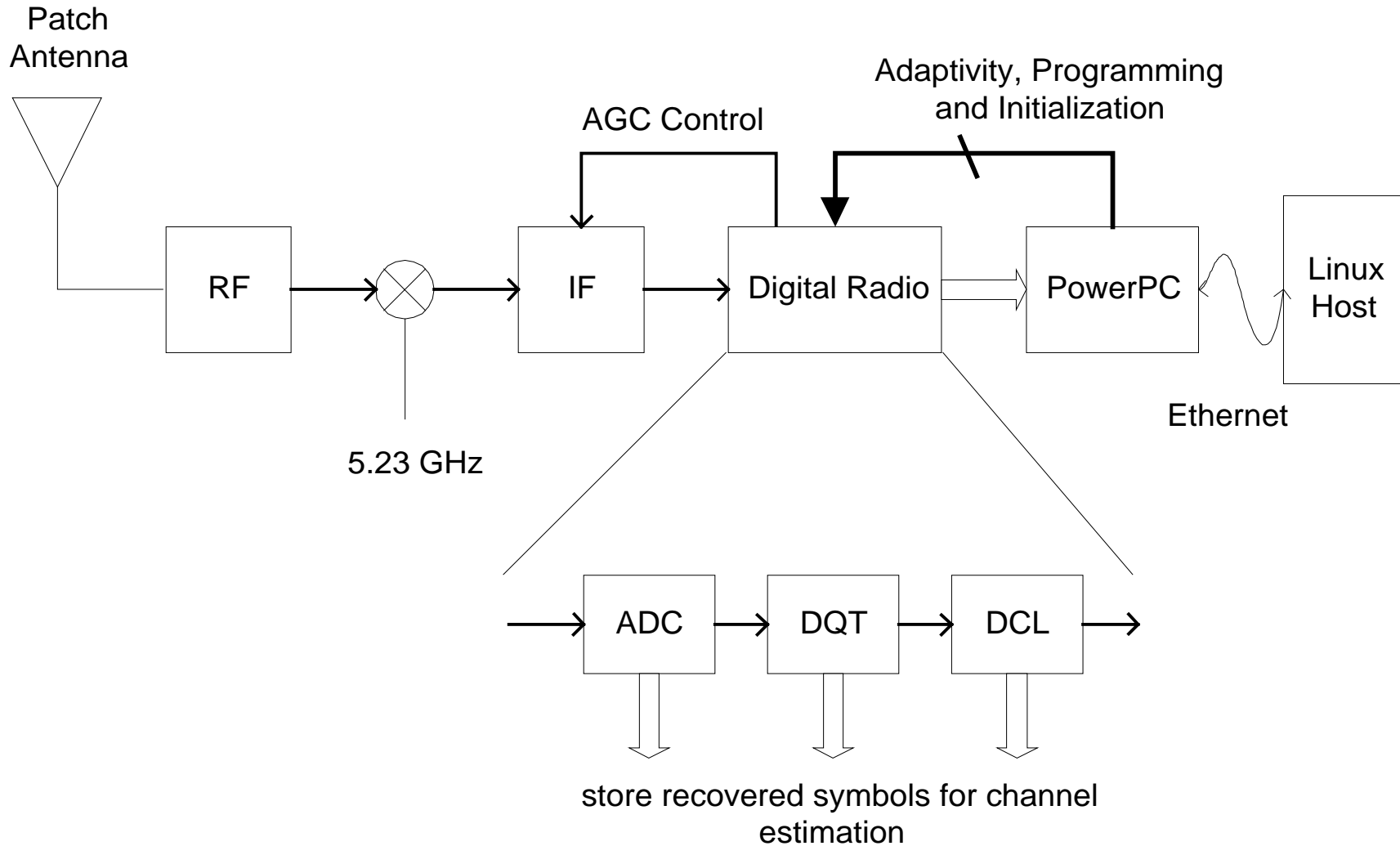



Benefits to Digital Demodulation

- No need for tuning filters
- Can Construct Linear Phase Filters
- Flexible BW selection
- Multiple Modulation Formats can be supported
- System can be simulated “exactly”
- Multiple Radio “Personalities” as easy as setting up tables



Control Bus Architecture

Control Bus is a serial bus controlling:

- PLL programming
- Programmable Attenuators
- Beamforming

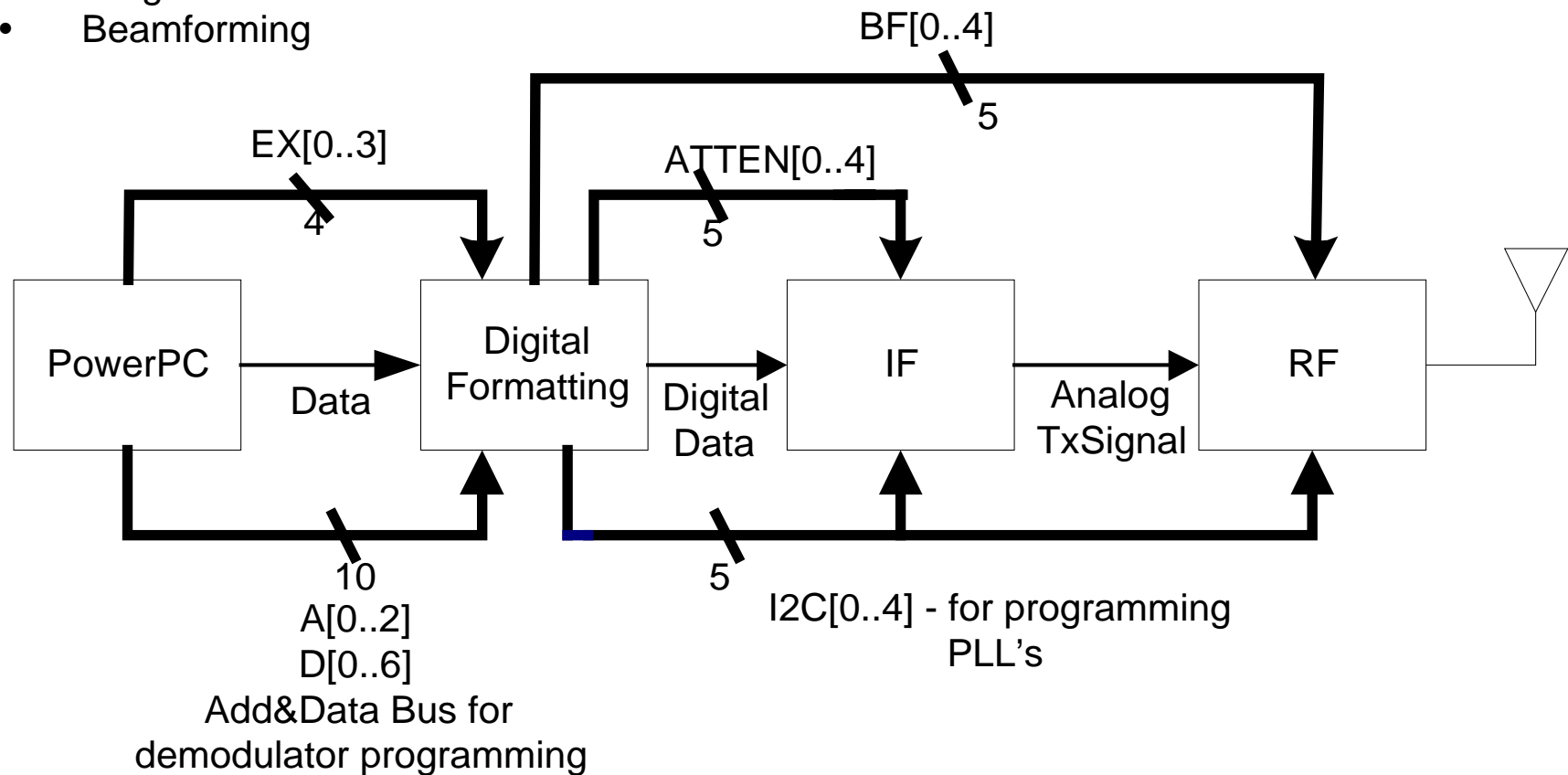

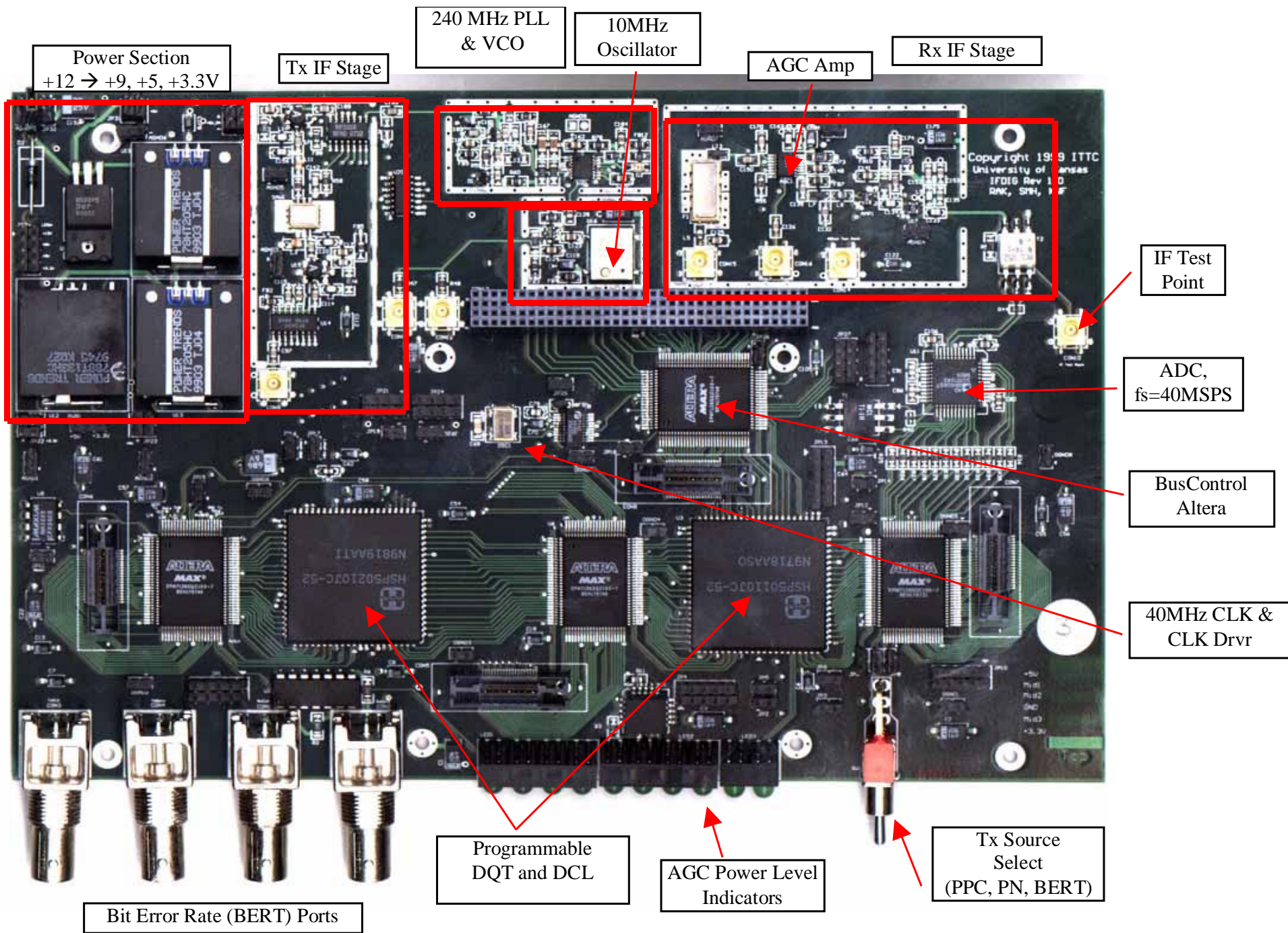



5.3 GHz Modular RF Front End

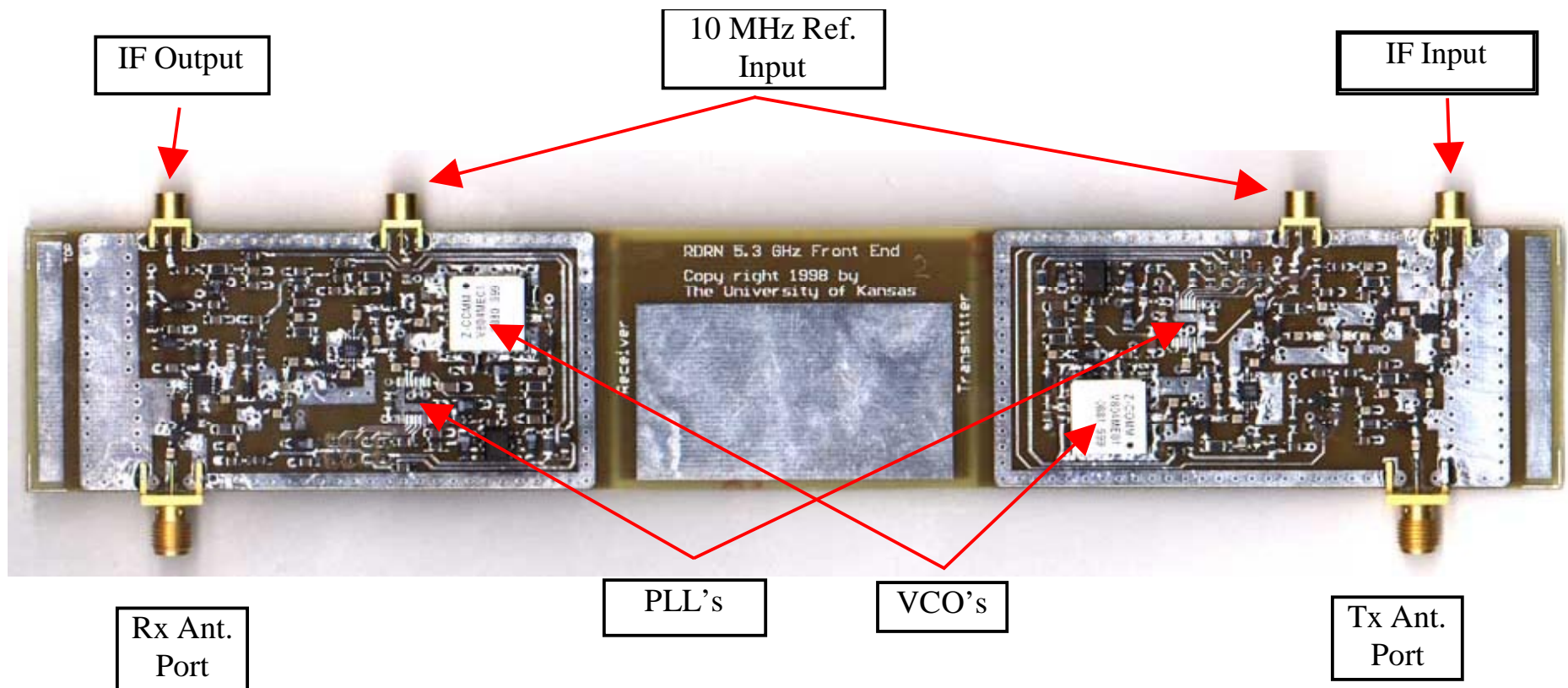



Average Power Requirements

	Voltage [V]	Current [A]	Power Needed [W]
Regulators (alone)	12	40m	0.480
Analog Sections	12	120m	1.44
9V sections	12	190m	2.28
Total for Analog Sections	12	350m	4.2
5V Digital. (Quiescent Only)	5V	1.6	8
3.3V Digital. Powering only Altera's (Quiescent Only)	3V	333m	1
Total Power for Digital			9 W
Total Power PPC (Quiescent), datasheet claims 8W			5 W
Total Power	12 V	1.52 A	18.2 W



Receiver Implementation

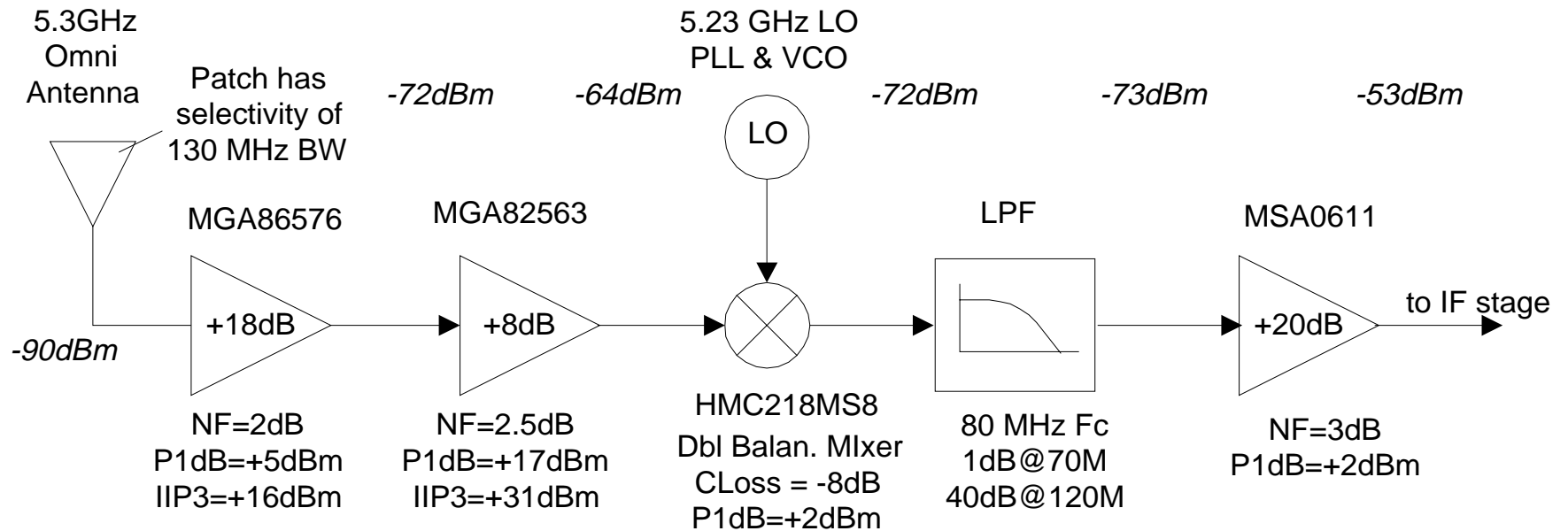



Patch Antenna Sub-Assembly

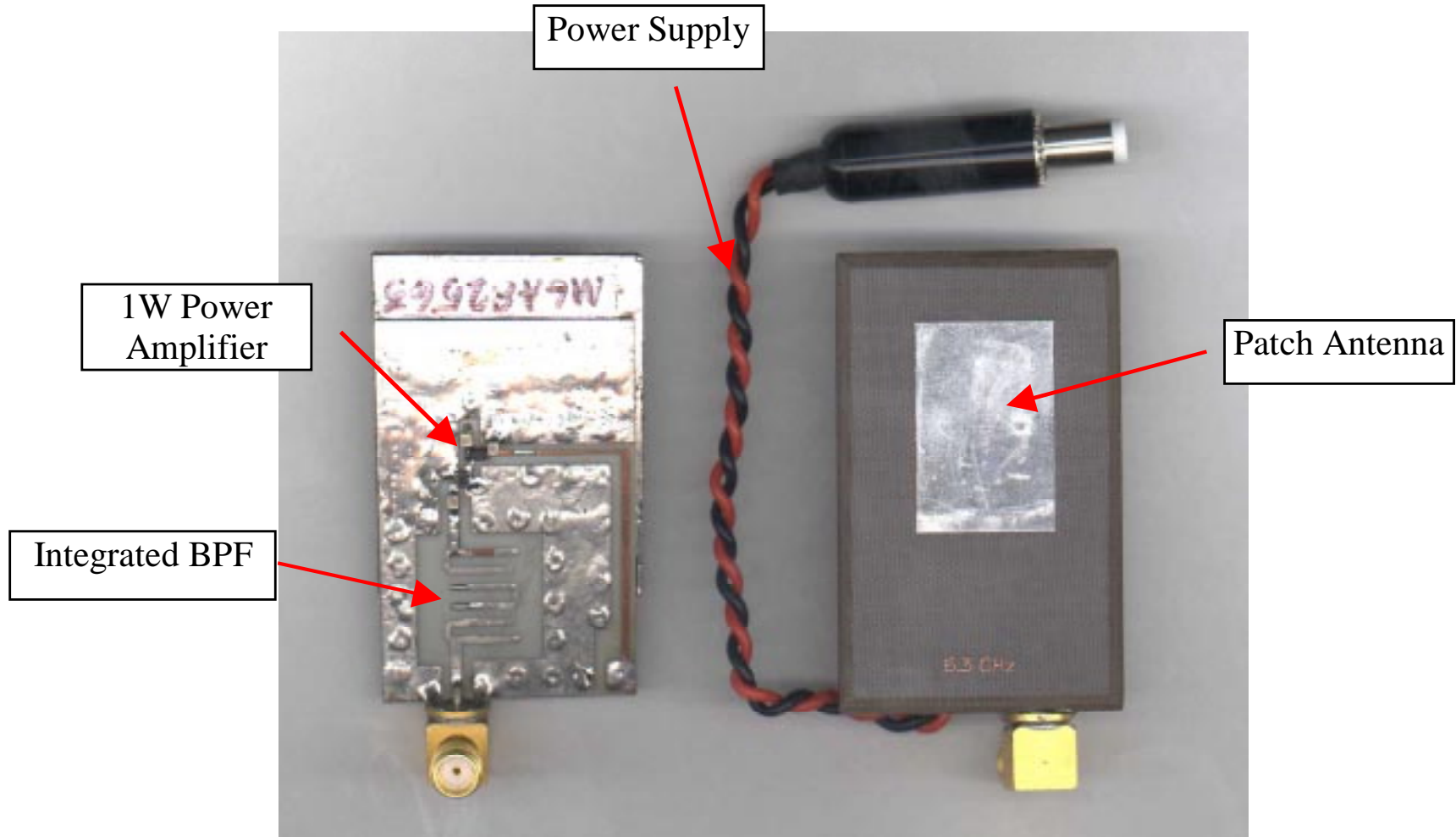



View of RF Receiver

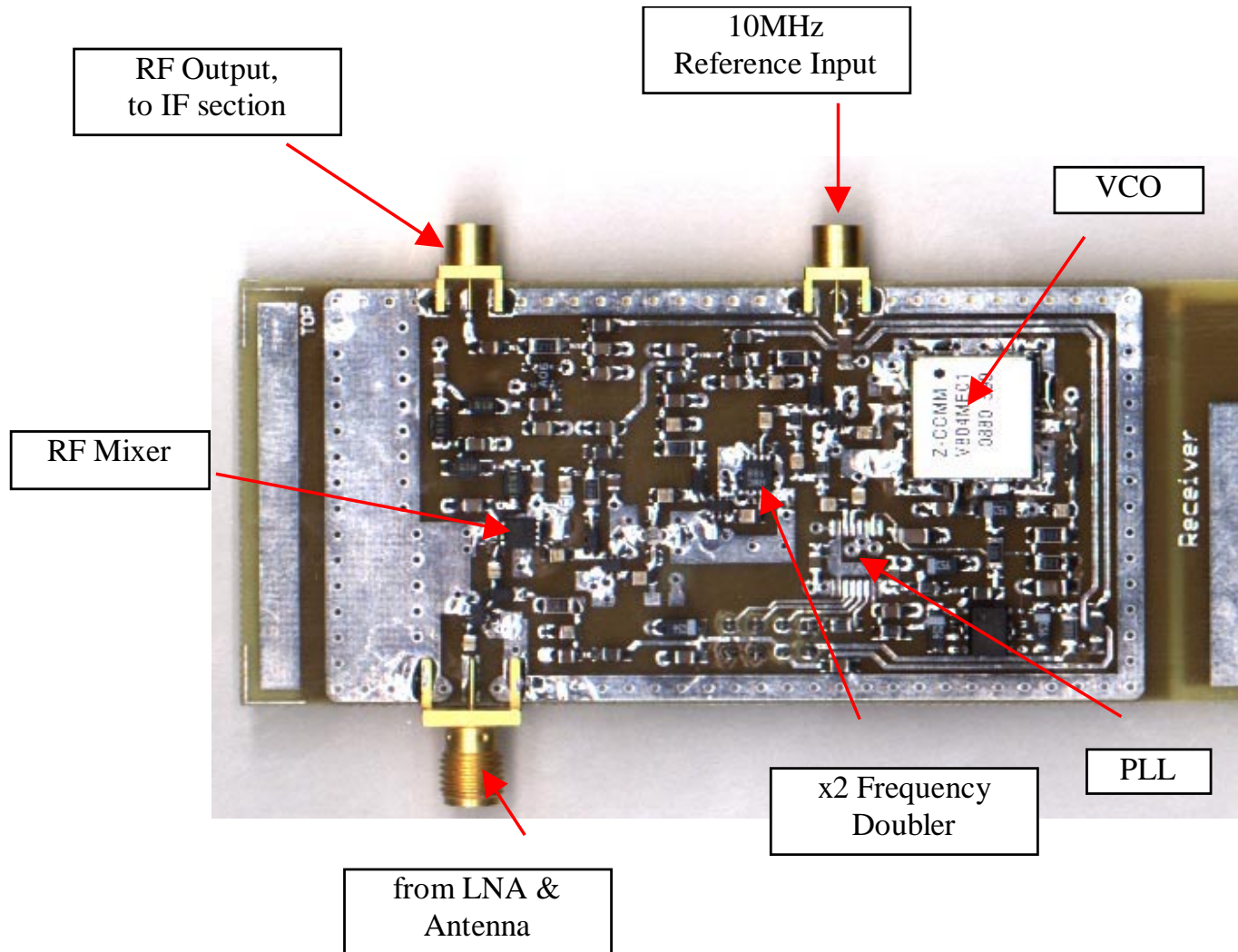



Input Signal Levels Throughout Receive Chain

P_{TX} @
1W

Stages within Receive Chain – all Input Power Levels in dBm

	LNA	82563	Mixer	LPF	0611	SAW	AGC	BPF	0611	2011	BPF	ADC
Desired Signal – Min	-90	-72	-64	-72	-73	-53	-63 (+24)	-39	-40	-20	-2	-3
Desired Signal -- Max.	-26	-8	0	-8	-9	+11	+1 (-40)	“	“	“	“	“
Adjacent Channel at 10MHz Offset	-90	-72	-64	-72	-73	-53	-83 (+24)	-59	-60	-40	-22	-23
	-26	-8	0	-8	-9	+11	-19 (-40)	-59	-60	-40	-22	-23
Tx Signal 50M offset, 1W, 50dB* isolation	-20	-2*	+6	-2 (-40)	-42	-22 (-50)	-72 (+24)	-48	-49	-29	-11	-12
							-72 (-40)	-112	-113	-93	-75	-76



Receive Signal Levels

Power Levels for Various Signals throughout Receive Stages

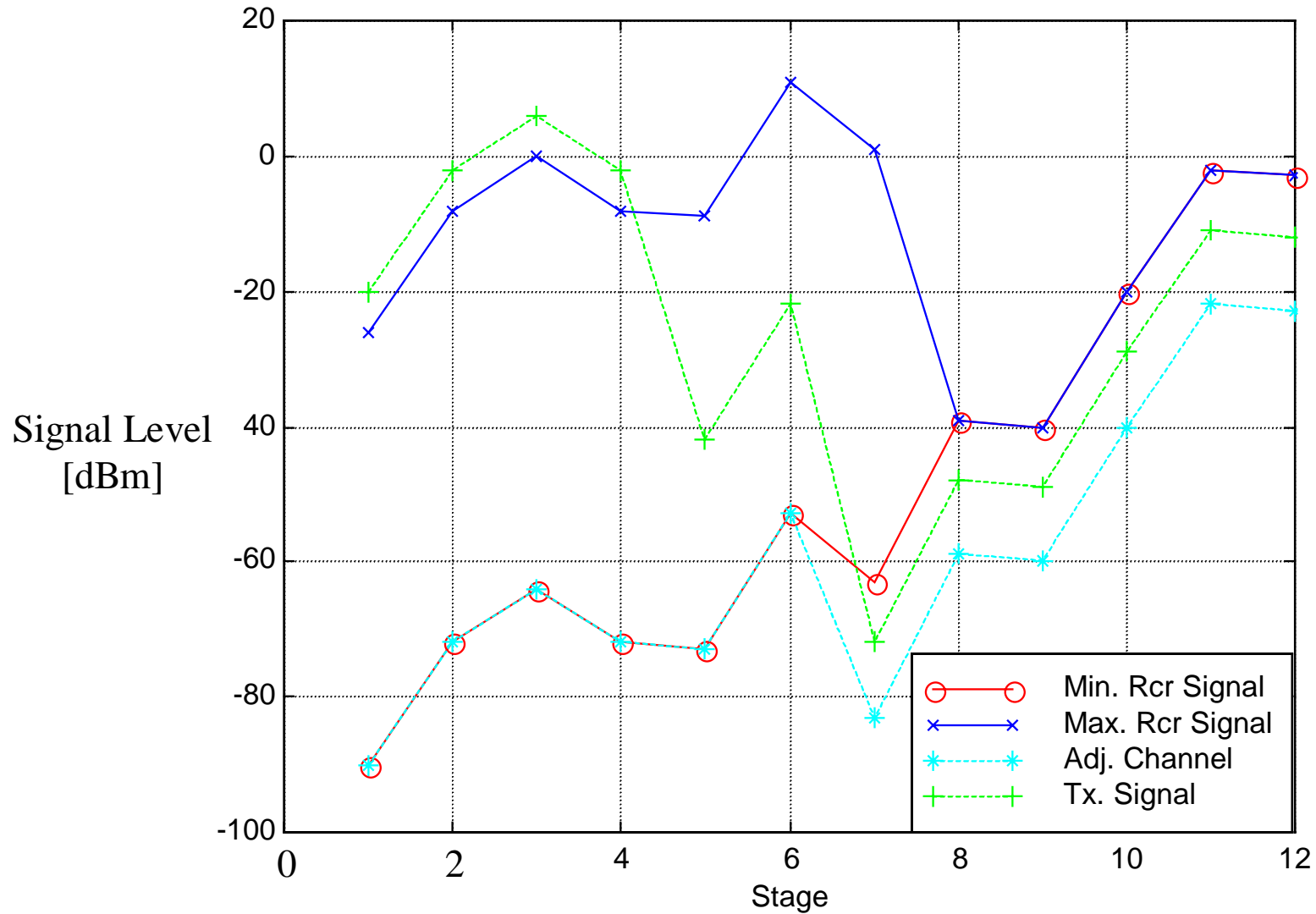



System Noise Figure

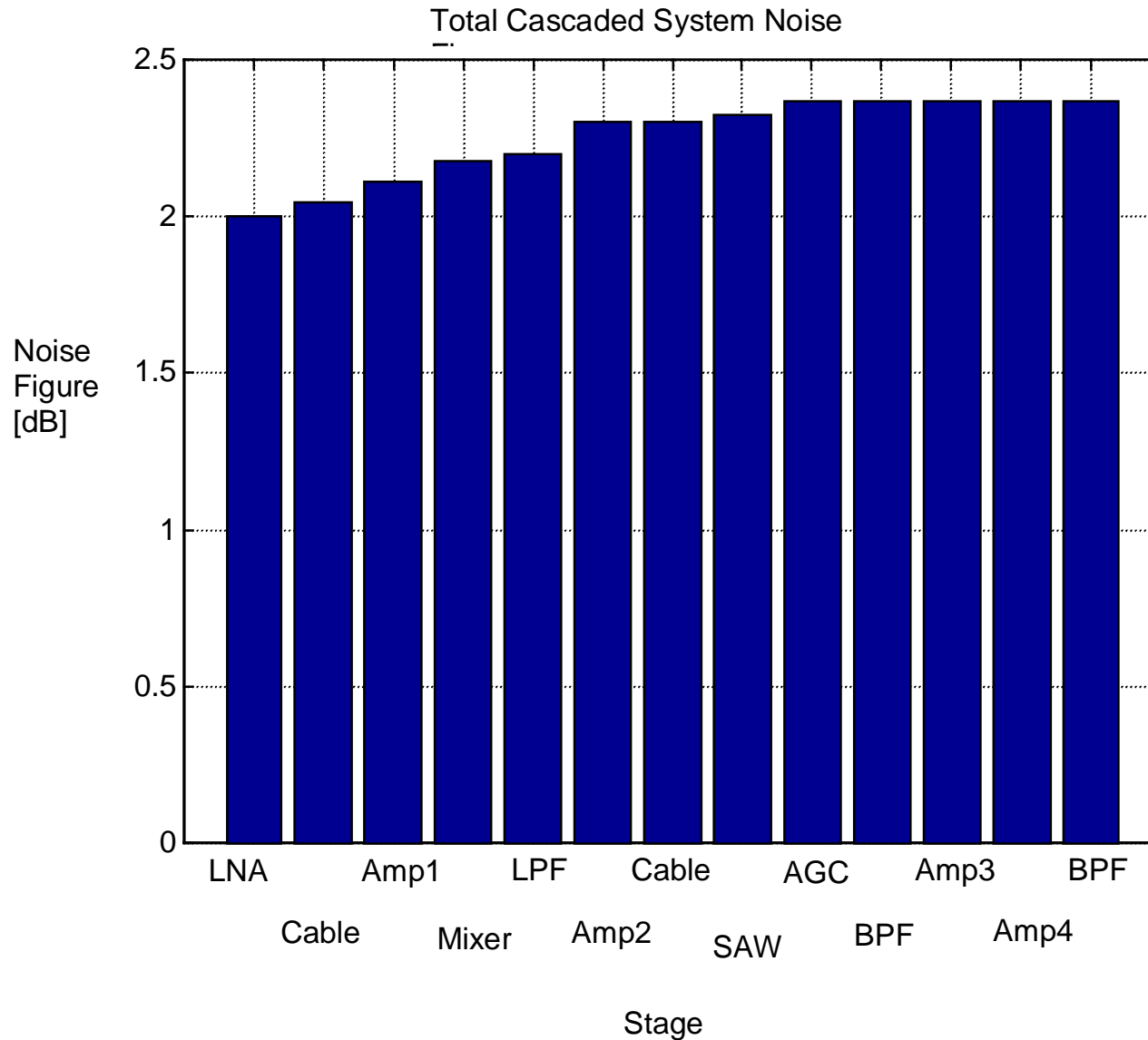



Receiver, IF to ADC

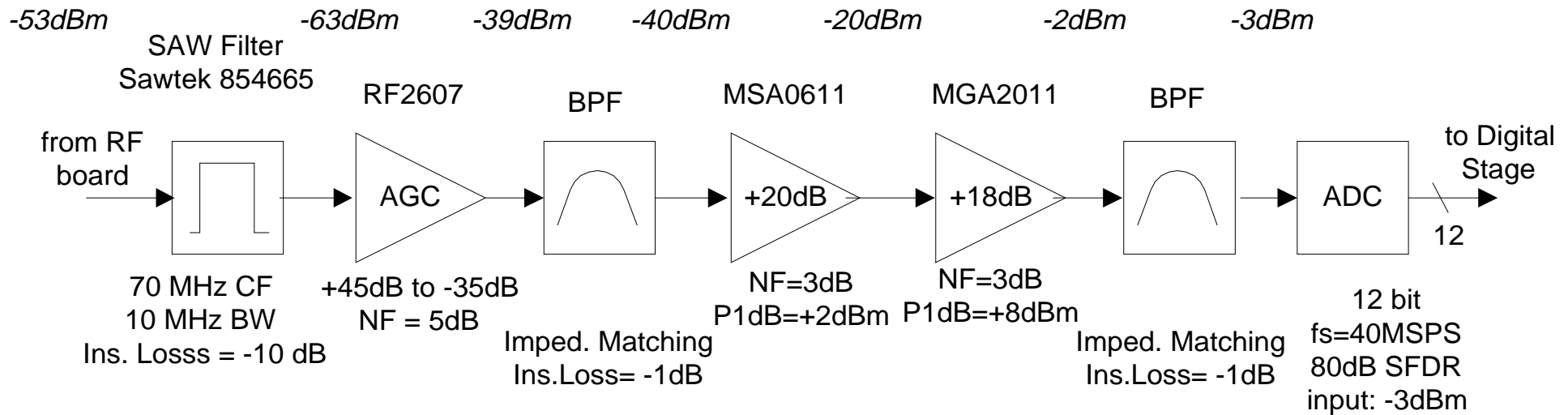



Receiver, IF to ADC

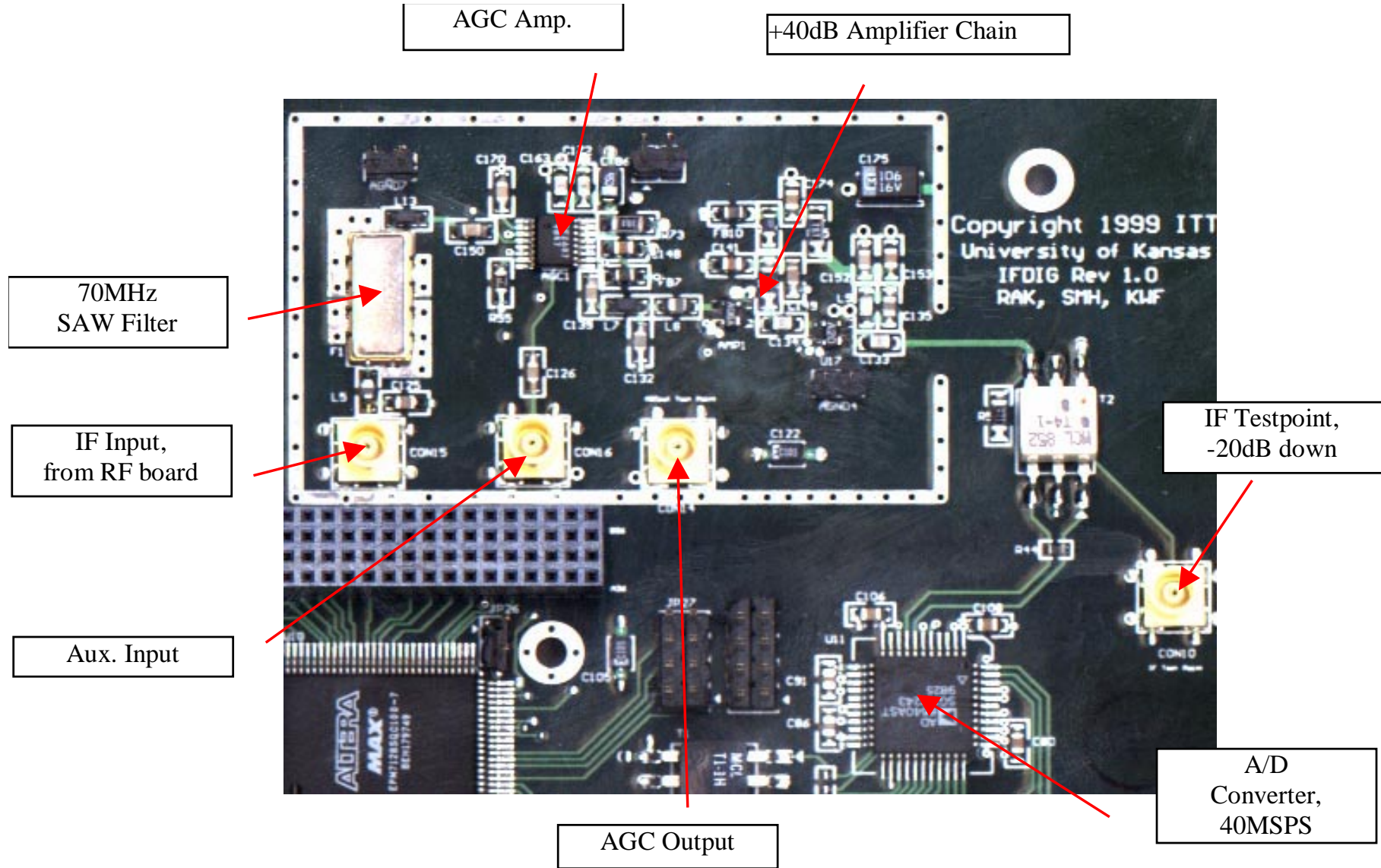



Digital Section

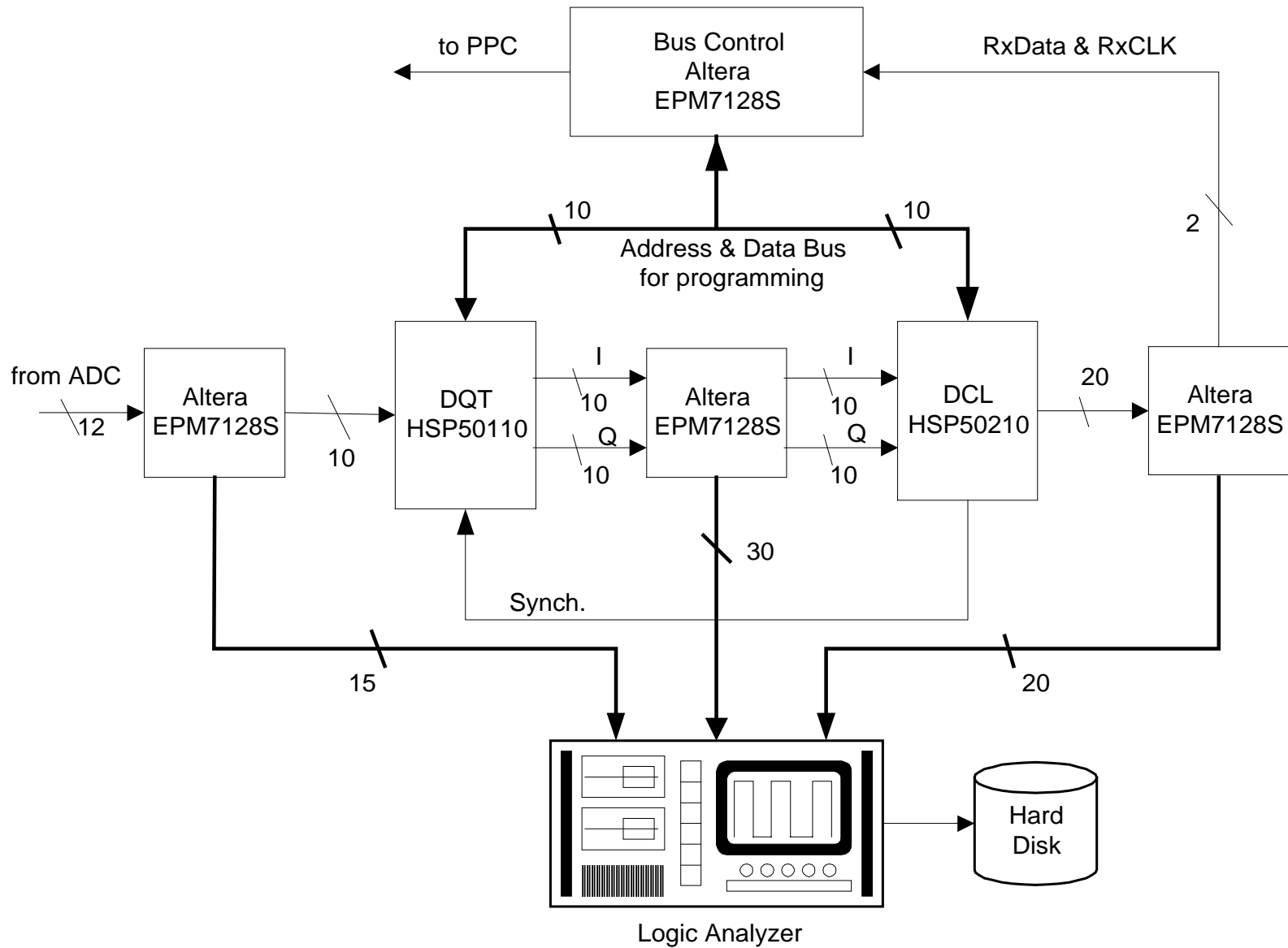



Digital Quadrature Tuner

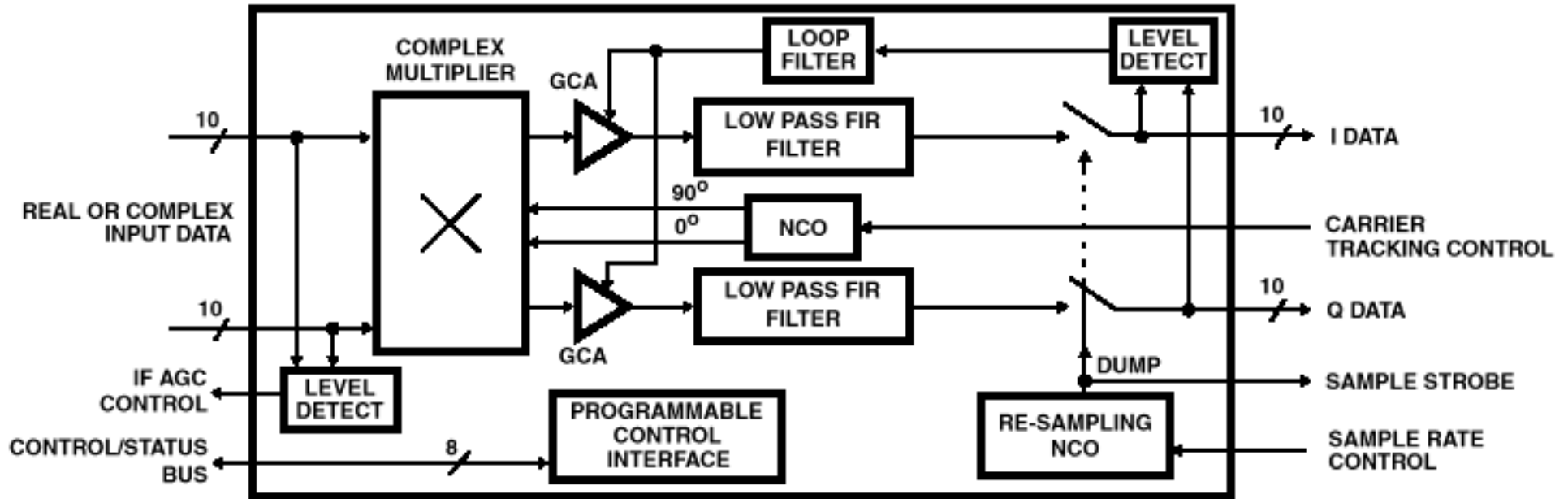

Digital Costas Loop

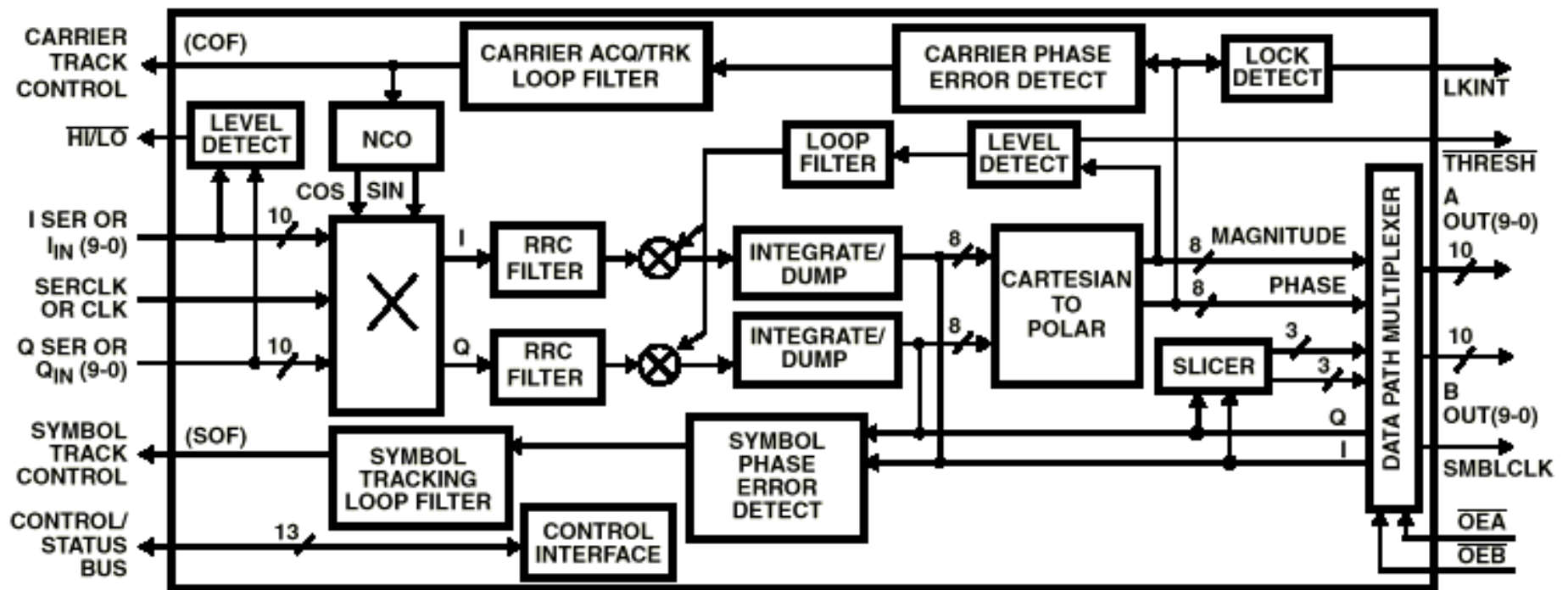



Digital Section

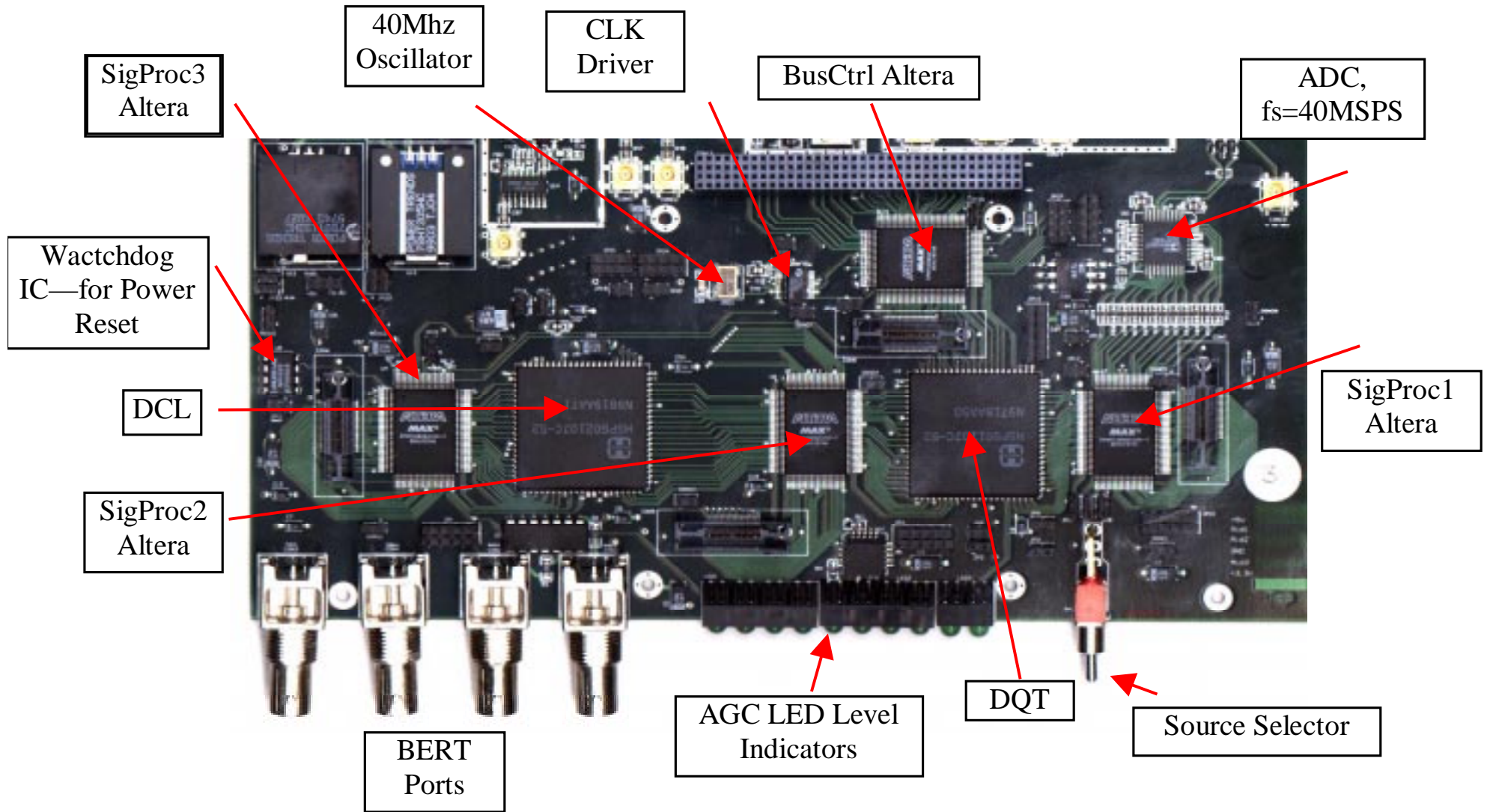



Transmitter Implementation (Baseband to IF)

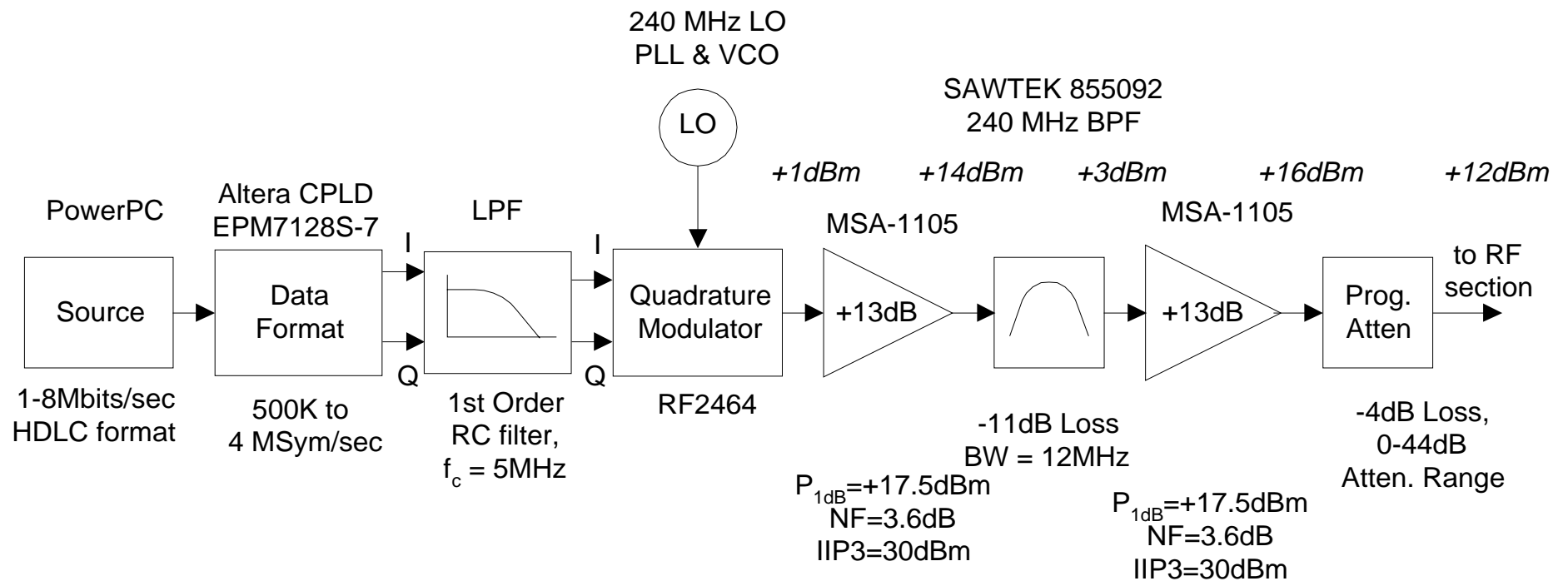



Close Up View of Tx IF Stage

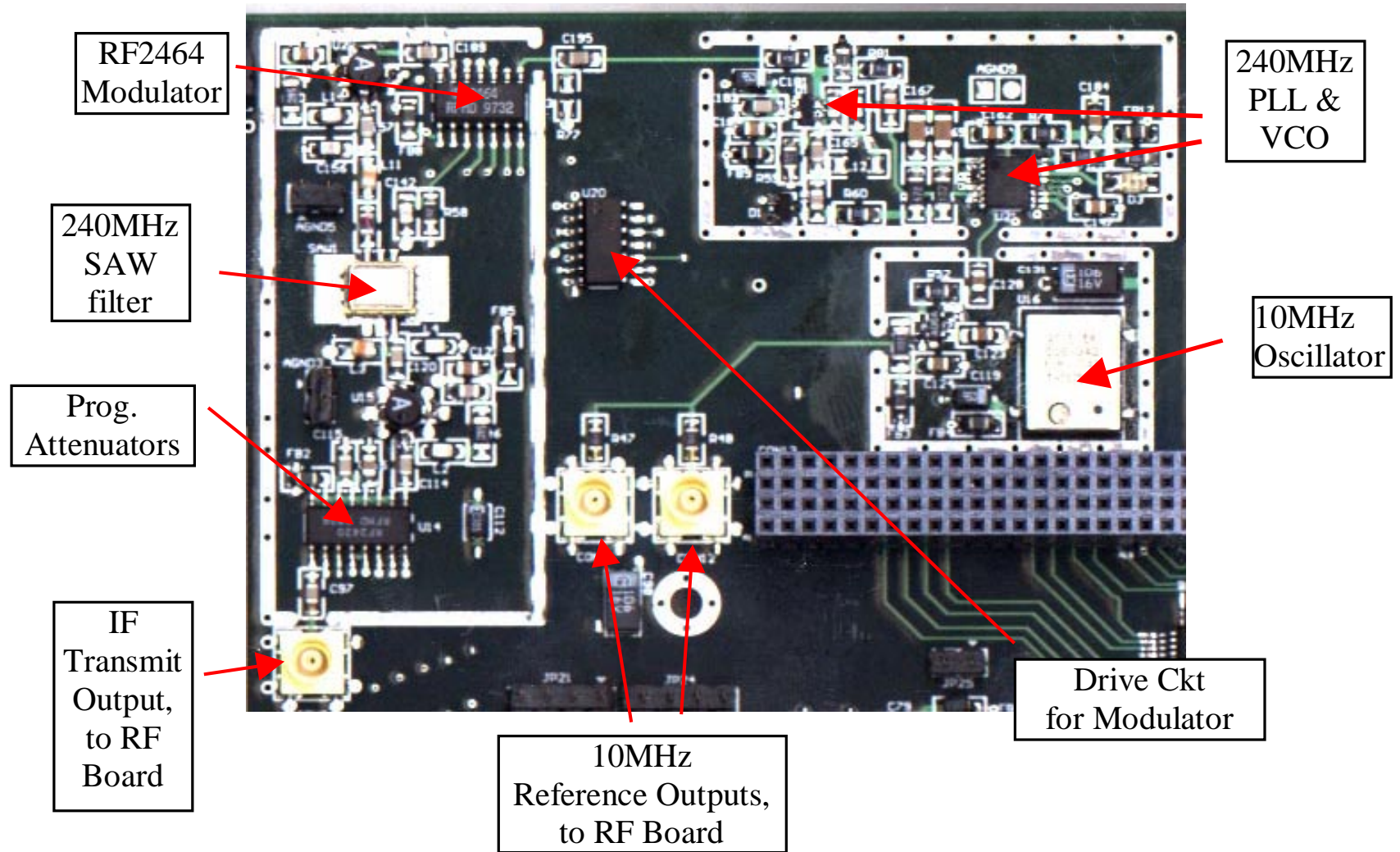



Transmit RF Section

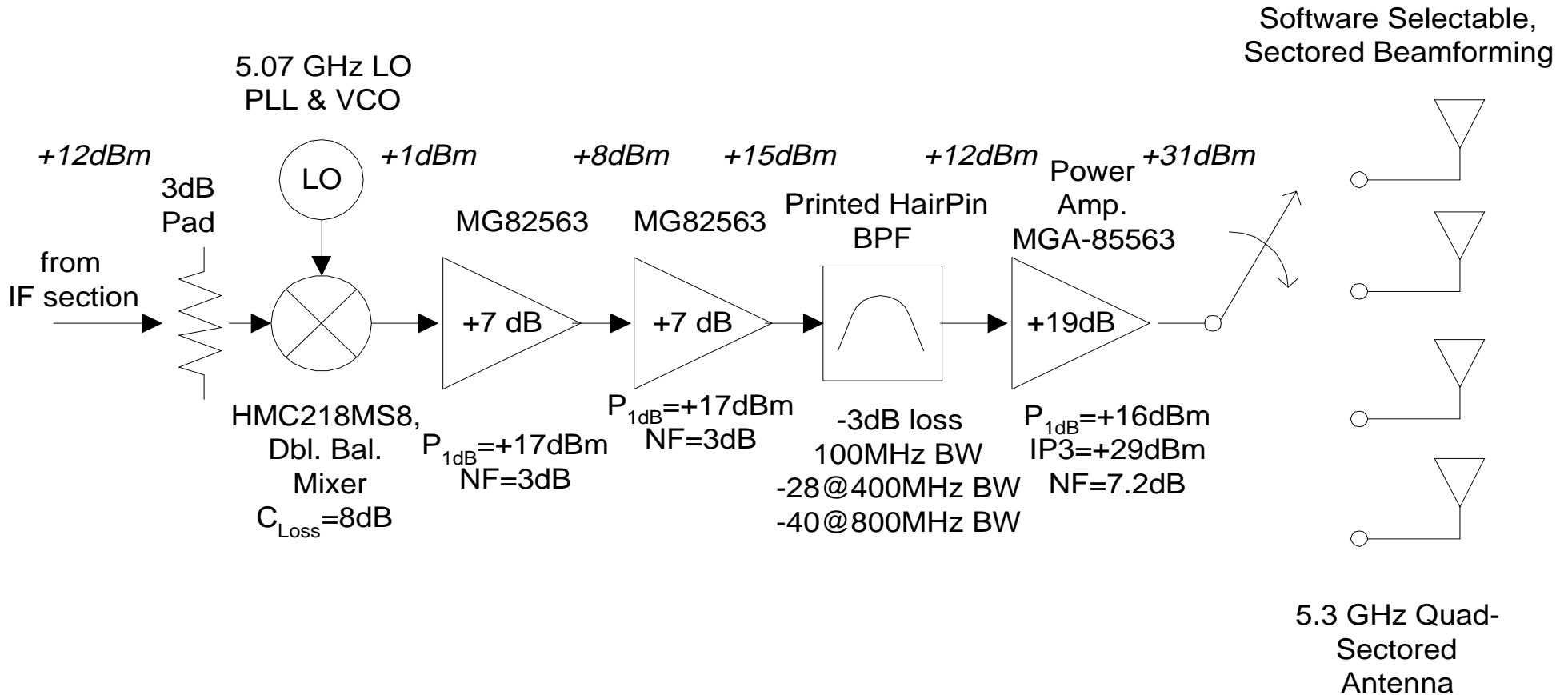



Transmit RF

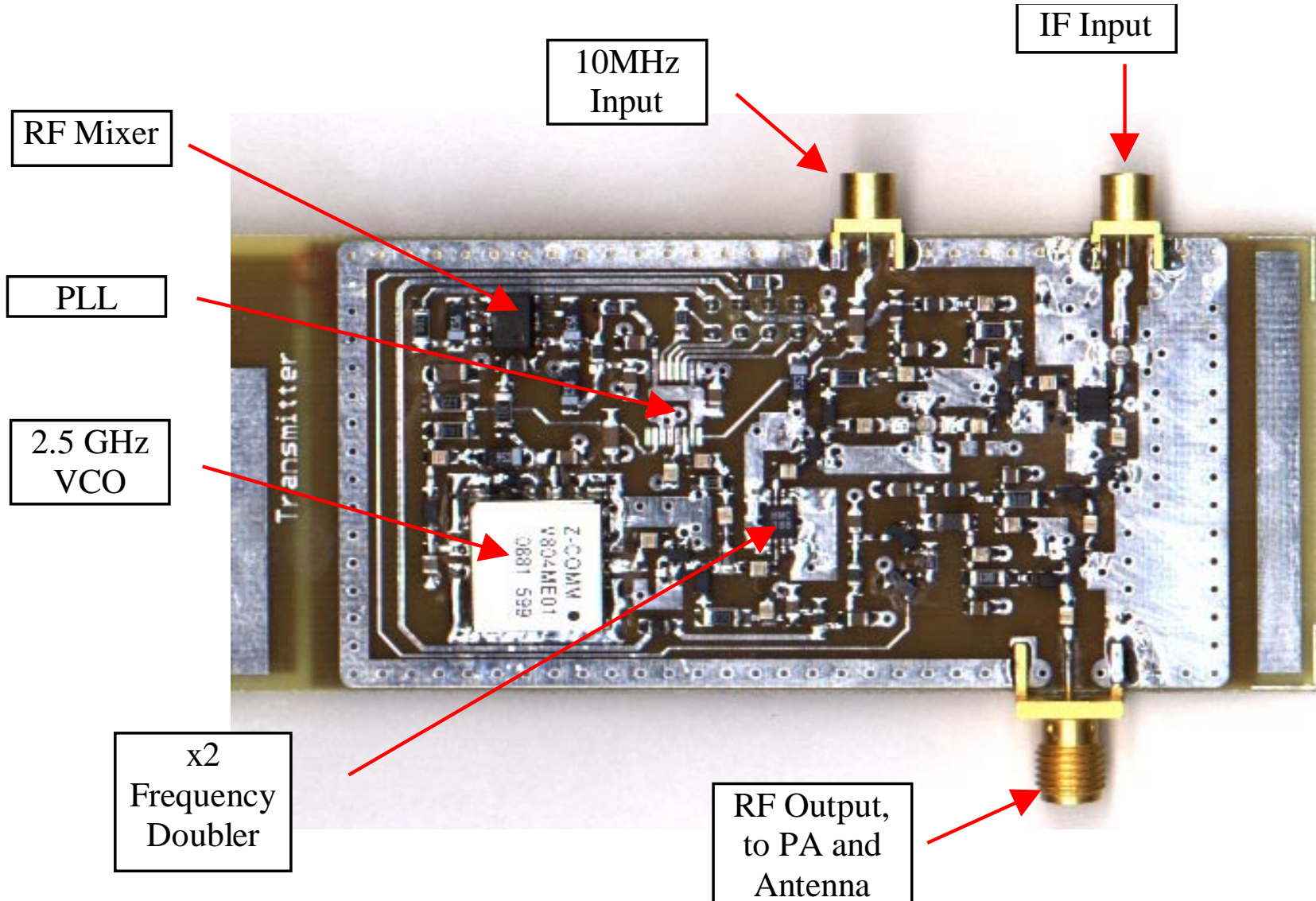



Summary

- Software controlled radio with modular RF front ends for use in channel estimation.
- High-Speed (up to 8 Mbps) wireless radio which is capable of physical layer and data-link layer adaptability.

Future Work

- Use this radio “platform” to develop protocols and algorithms to control the physical & data-link layer.
- Real time channel estimation and the use of these parameters in the above adaptation algorithms.



Sub-Sampling

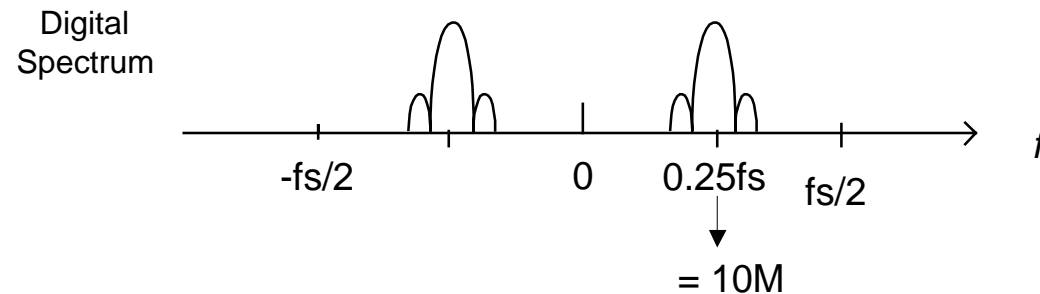
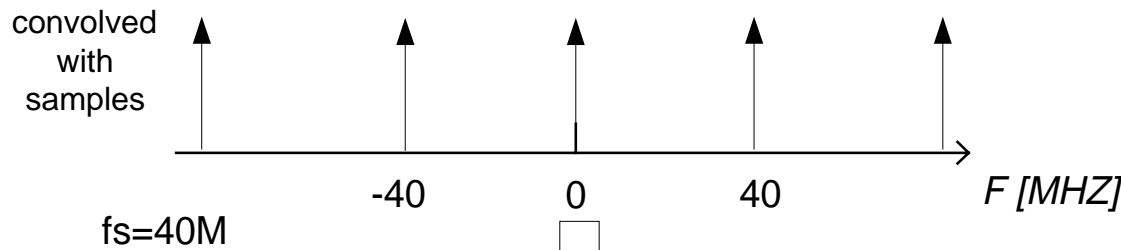
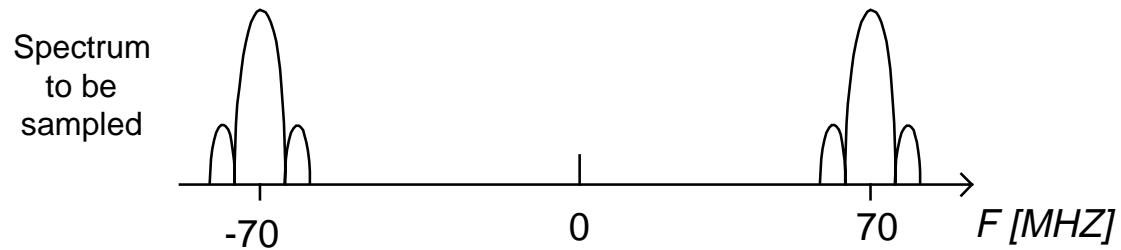

How to choose f_s ,

$$\frac{2f_H}{k+1} < f_s < \frac{2f_L}{k}$$

where the maximum value of k is :

$$k < \frac{f_L}{f_H - f_L}$$



Decimation

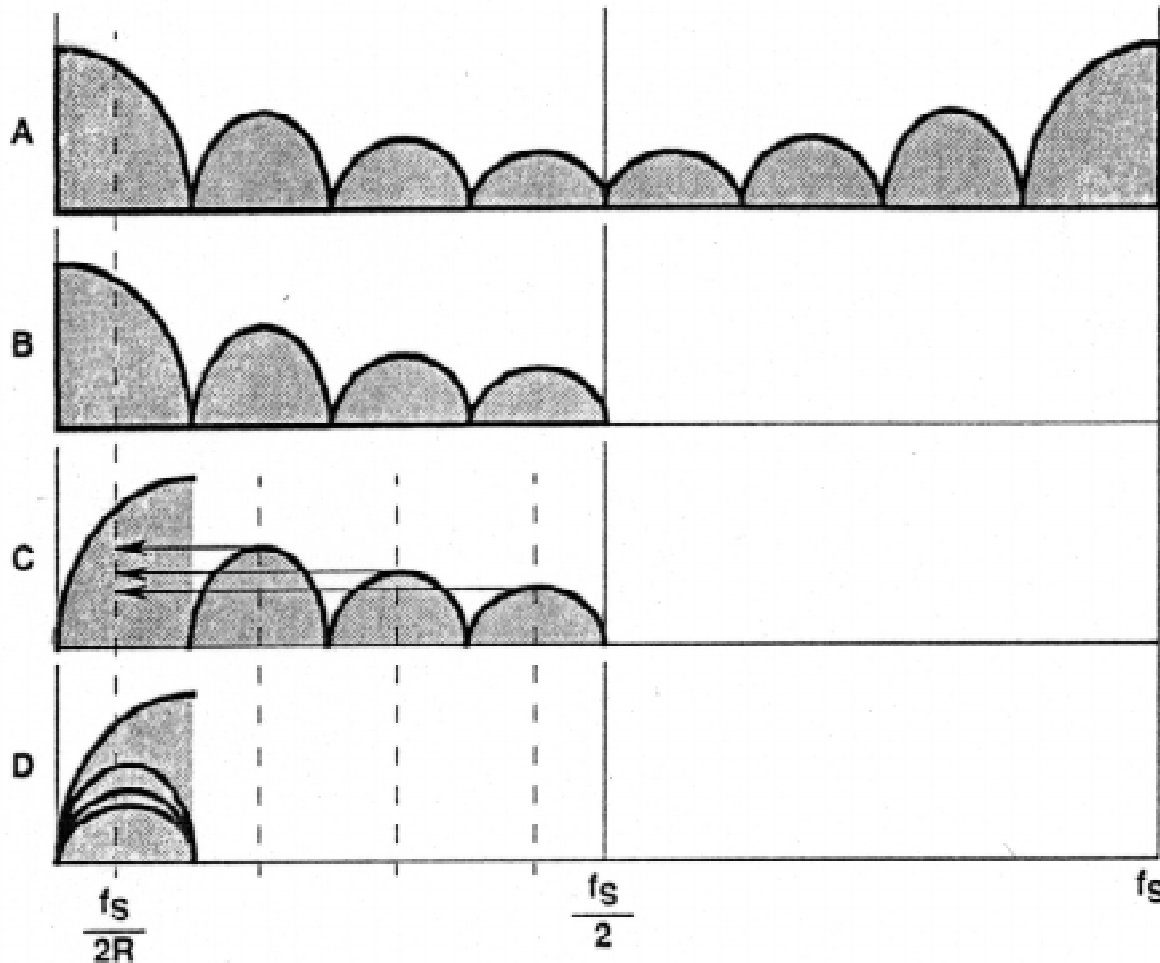

Apparent useable BW

Can Only see up to $\frac{f_s}{2}$

Decimation creates new
“folding frequency”

Noise and possible
interferers aliased into
passband?--How much
attenuation? Use Alias
Profile



Digital Quadrature Tuner, detail

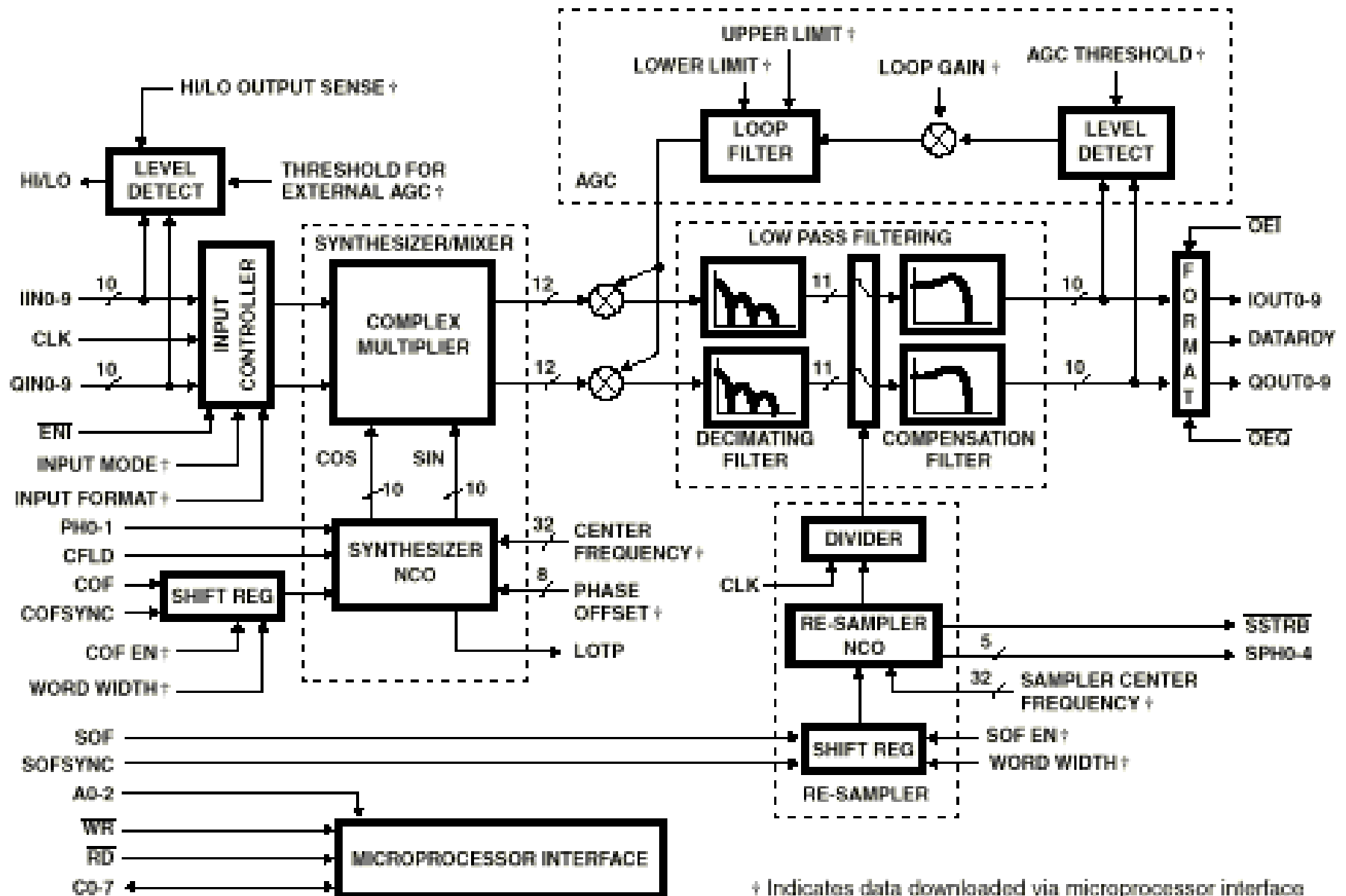



Digital Costas Loop, detail

