

Survivability Architectures for Service Independent Access Points to Multi- wavelength Optical Wide Area Networks

Master's Thesis Defense

Ananth Nagarajan

EECS Department, University of Kansas

10/13/98

Outline

- Introduction, Motivation and Goals
- Service Independent Access Points (SIAP)
- Restoration Schemes for WDM, SONET, ATM and IP
- Survivability Approaches
 - Service-Oriented
 - Transport-Oriented
- Spare Capacity Allocation Approaches
 - Traditional
 - Pre-emptive
- Degree of survivability $s(t)$
- Algorithm for evaluation of Survivability Approaches
- Example Network
- Results
- Conclusions and Future Work

Introduction, Motivation and Goals

- WDM technology allows transport of huge amounts of data of varying formats (IP, ATM, SONET) via fewer network elements.
- More customers affected by single failures (fiber cut, laser failure etc.) leading to loss of revenue.
- Necessary to provide network infrastructure that is fault tolerant and self healing, to allow quick failure recovery.
- Multiple services (like IP, ATM and SONET) that are affected by failure, have varying survivability requirements.
- Is a single unified restoration approach capable of restoring all services?

Introduction, Motivation and Goals (contd.)

- Single solution not feasible. Multiple restoration schemes for various services must co-exist.
- Need to design a survivability architecture where different restoration schemes are activated for different failure types.
- The architecture must
 - reduce initial investment
 - reduce the spare capacity requirement for survivability
 - increase restoration speed
- WDM also offers the capability to have service transparency in networks. Need to study the impact of service transparency on the efficiency of the survivability architectures.

Introduction, Motivation and Goals (contd.)

- Goals

- Develop an algorithm for evaluating survivability approaches and spare capacity assignment approaches for an optical WAN.
- Algorithm involves comparing the efficiency (w.r.t. spare capacity requirements and restoration times) of
 - **transport-oriented** restoration v/s **service-oriented** restoration
 - **traditional** spare capacity allocation v/s a **new** approach (discussed later)
 - **service transparent** networks v/s **layered** networksusing well-known restoration schemes for different services.
- Make recommendations based on the results of the above evaluation.

Service Independent Access Points (SIAP)

- Being developed at KU, to provide service independent access directly to WDM-based optical WANs.
- Involves optical framing (fixed length frames assumed) with simple headers and addressing, to transport multiple services transparently.
- Consists of
 - Protocols Engine - to convert existing services to OWAN transmission protocol
 - Optical Processor - to encode transmitted frames (and decode received frames)
 - Link Quality Monitor - to provide optical OA & M, using separate Supervisory wavelength channel
 - Optical Regenerators, WADMs and Protocol-specific engines

SIAP architecture

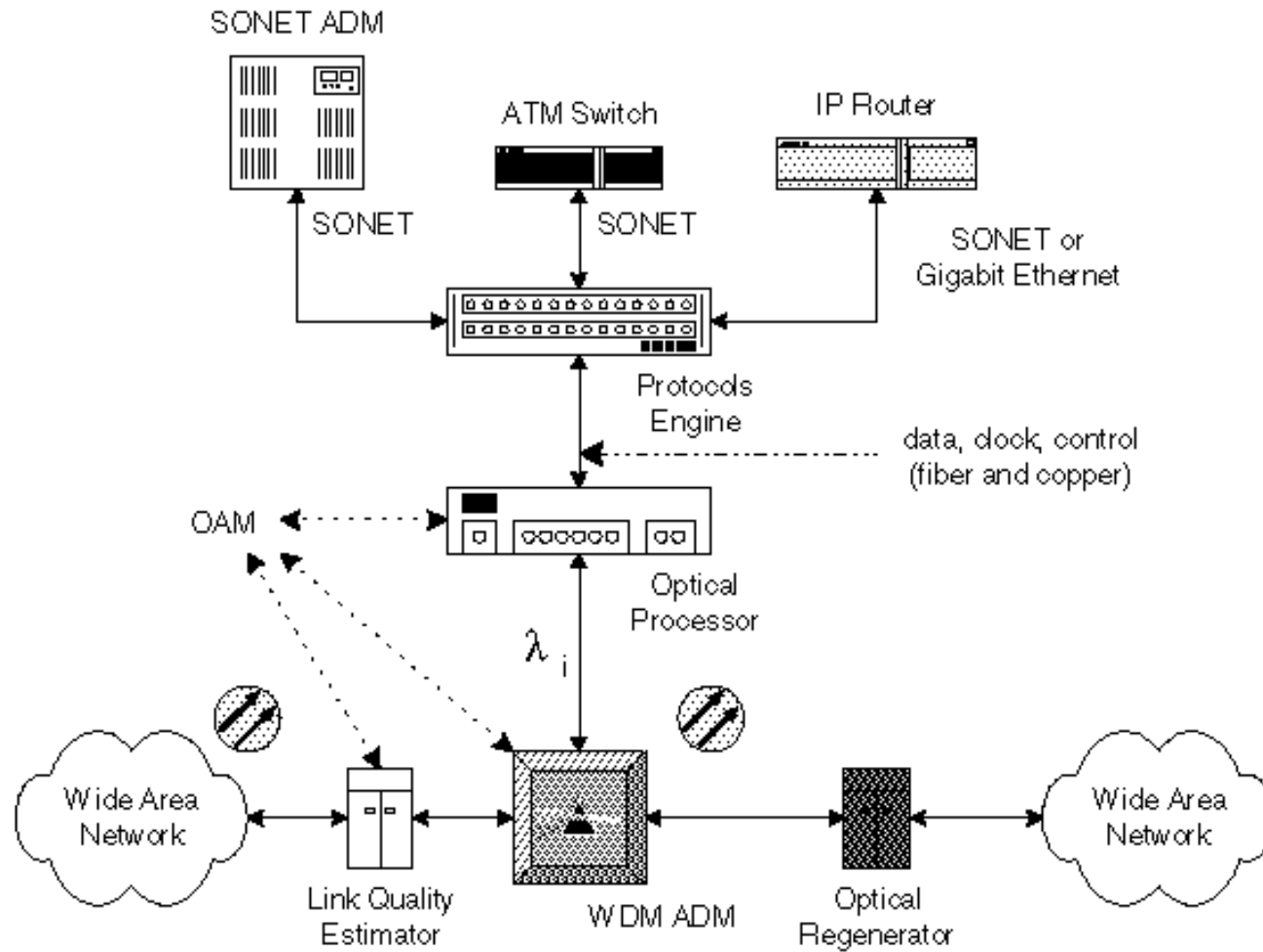

Restoration Schemes for WDM, SONET, ATM and IP

– General Comments

- Failed services are restored using spare capacity
- Sufficient spare capacity required for desired survivability
- Spare routes must be planned along physically diverse paths
- Spare paths can be assigned either dynamically or pre-assigned
 - Dynamic spare path assignment is time consuming and restoration time is increased.
 - Although pre-assigned spare paths are not flexible, we opt for these in order to reduce restoration time.

Restoration Schemes for WDM, SONET, ATM and IP

- WDM Restoration

- Virtual Wavelength Path (VWP) scheme to allocate wavelengths link-by-link, hence, local wavelength assignment, as opposed to global.
- Layered optical network is shown below:

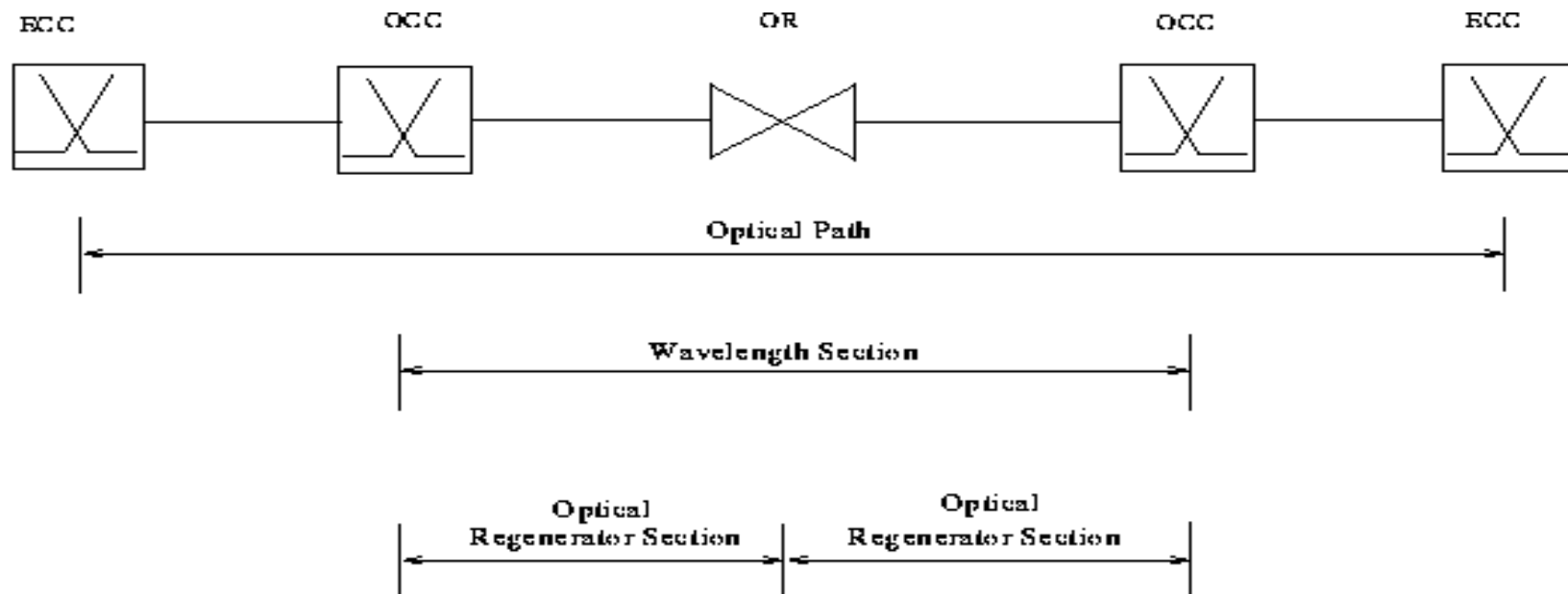

ECC - Electrical Cross-Connect
OCC - Optical Cross -Connect
OR - Optical Regenerator

Restoration Schemes...(contd.)

- WDM Restoration (contd.)
 - Wavelength section protection done using wavelength path switching.
 - Restoration time (**in milliseconds**) is given by:

$$t_r^{WDM} = t_{frame} + \frac{N_w l}{2 \times 10^2} + (N_w \times t_{proc}^{WDM}) + (t_{sw}^{WDM} \times S_T \times D_{aw})$$

where

$$t_{frame} = 125 \mu s$$

N_w = number of nodes to be informed of failure

l = avg. inter - node distance in km.

t_{proc}^{WDM} = per - node processing delay ≈ 3 ms.

t_{sw}^{WDM} = VWP switching time ≈ 20 ms

D_{aw} = Affected number of VWPs

Restoration Schemes...(contd.)

- SONET Restoration
 - SONET has inherent features for survivability
 - Initiation Criteria like Signal Failure and Signal Degrade required.
 - These trigger off alarms, which are used for Protection Switching
 - K1 and K2 bytes in Section Overhead used for Protection
 - SONET Protection Schemes:
 - In case of ring topology
 - use Self Healing Ring (SHR). Usually Bidirectional 4-fiber SHR is used (BSHR/4)
 - Large networks can be configured to look like several interconnected SHRs.
 - If ring topology not available
 - use 1:1 Automatic Protection Switching with Diverse Protection (1:1 APS/DP)
 - expensive, but 100% survivable

Restoration Schemes...(contd.)

- SONET Restoration (contd.)
 - Restoration time (**in milliseconds**) is given by:

$$t_r^{SONET} = t_{det}^{SONET} + \frac{N_s l}{2 \times 10^2} + (3 \times t_{proc}^{SONET}) + (t_{sw}^{SONET} \times s_T \times D_{as})$$

where

$$t_{det}^{SONET} \approx 3 \text{ ms}$$

N_s = number of nodes to be informed of failure

l = avg. inter - node distance in km.

$$t_{proc}^{SONET} = \text{processing delay} = 0.375 + (N_s \times 0.250) \text{ ms.}$$

$$t_{sw}^{SONET} = \text{SONET path switching time} \approx 20 \text{ ms}$$

D_{as} = Affected number of SONET VWPs

Restoration Schemes...(contd.)

- ATM Restoration
 - Intrinsic features for fast restoration:
 - Cell-level error detection in the form of Header Error Check (more checks in unit time because of small size of ATM cell)
 - Inherent rate adaptation and non-hierarchical multiplexing stages within the network, implies increased link capacity utilization.
 - Faster reconfiguration with lower spare capacity requirement.
 - Use Fast VP restoration
 - pre-assign spare VPs for working VPs
 - spare VPs are assigned zero bandwidth initially
 - In the event of failure, switch failed connections to spare VPs after assigning required bandwidth
 - Sufficient spare capacity needs to be pre-assigned to allow complete restoration

Restoration Schemes...(contd.)

- ATM Restoration (contd.)
 - Restoration time (**in milliseconds**) is given by:

$$t_r^{ATM} = t_{det}^{ATM} + \frac{N_a l}{2 \times 10^2} + (N_a \times t_{proc}^{ATM}) + (t_{VP} \times s_T \times D_{aa})$$

where

$$t_{det}^{ATM} \approx 0.1ms$$

N_a = number of nodes to be informed of failure

l = avg. inter - node distance in km.

t_{proc}^{ATM} = per - node processing delay ≈ 1 ms.

t_{sw}^{WDM} = VP switching time ≈ 0.1 ms

D_{aa} = Affected number of ATM VWPs

Restoration Schemes ...(contd.)

- IP Restoration

- Use Cisco's Hot Standby Router Protocol (HSRP)

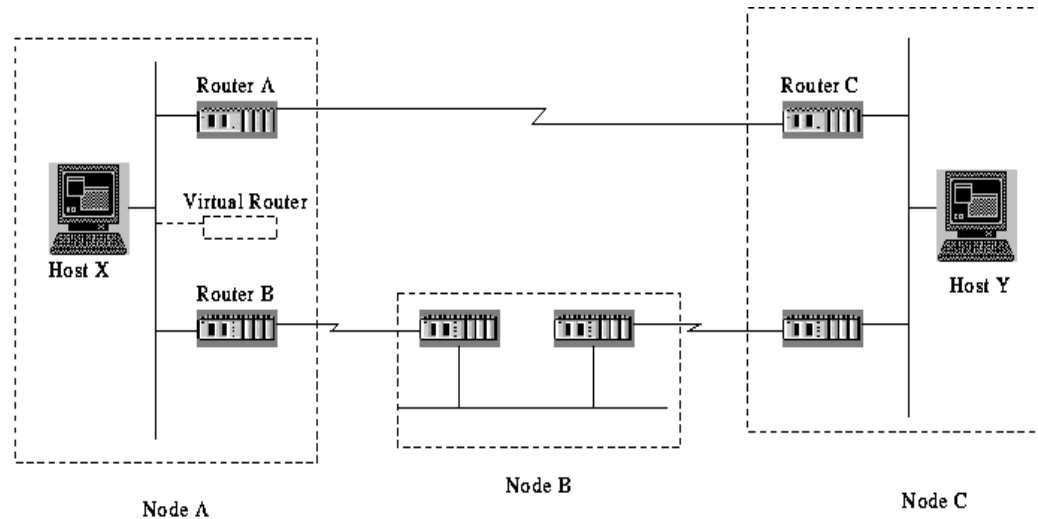

- Host X is configured with Virtual router as default router, A as active router.
- Router A has IP address and MAC of virtual router, and sends any packets addressed to virtual router to Host Y
- Router B is also configured with IP and MAC addresses of virtual router. B assumes the duties of A when A stops working.
- Priority scheme used to assign active router.
- HELLO messages exchanged to advertise priorities and availability

Restoration Schemes...(contd.)

- IP Restoration (contd.)
 - Restoration time (**in milliseconds**) is given by:

$$t_r^{IP} = 1000 + \frac{N_i l}{2 \times 10^2} + (N_i \times 3) + (12 \times s_T \times D_{ai})$$

where

N_i = number of nodes to be informed of failure

D_{ai} = Affected number of IP VWPs

Survivability Approaches

- Service-oriented Approach
 - Restoration is performed by services affected by the failure, irrespective of where the failure occurs.
 - Advantages:
 - Single recovery scheme to restore traffic of a certain type. Interworking of different survivability schemes avoided, easier control and management
 - Easier to provide multiple degrees of reliability for services with different survivability requirements
 - Disadvantages:
 - Failure propagation to higher layers, implies multiple restoration functions required at higher layers for single lower layer failure
 - Correlation of higher layer paths with lower layer connections makes spare capacity allocation difficult.
 - Routing of higher layer paths needs to be correlated with lower layer connections, as working and backup paths need to be physically diverse.

Survivability Approaches (contd.)

- Transport-oriented Approach
 - Restoration is performed at the layer where the failure occurs.
 - Advantages:
 - Multiple higher layer failures can be restored by single lower layer restoration. No special precautions need to be taken at service layers to cope with complex failure scenarios.
 - Since adequate resilience is provided to higher layer paths routed along a layer, additional higher layer protection requires less spare capacity than service-oriented approach. Hence, less wastage of higher layer equipment resources.
 - Disadvantages:
 - Multiple recovery schemes responsible to restore single service depending on where the failure occurs.
 - Additional functionality required to co-ordinate recovery actions at different layers, adding to network complexity.
 - Spare capacity provisioning, traditionally, is wasteful (will be seen next).

Spare Capacity Allocation Approaches

- Traditional (Layered) spare capacity allocation
 - Each layer is assigned spare capacity separately. For example, in an ATM/SONET/WDM architecture, we have separate spare ATM VPs, spare SONET paths and spare WDM VWPs.
 - Lower layer working paths have to accommodate higher layer working *as well as* higher layer spare paths.
 - Lower layer spare paths must protect the corresponding working paths. In effect, they protect higher layer working *as well as* spare paths. This leads to a “redundant redundancy”. Thus, more spare resources are required at lower layers.
 - Spare capacities of each layer are dedicated to protect that layer. Thus, SONET spare capacity cannot be used to perform ATM restoration. In other words, for an ATM layer failure, if the ATM layer runs out of spare capacity to perform restoration, ATM services may be lost even though sufficient equivalent spare capacity is available at the SONET layer.

Spare Capacity Allocation Approaches (contd.)

- Pre-emptive (common-pool) spare capacity allocation
 - Being developed at the University of Ghent, Belgium
 - All spare resources are shared, in a common-pool.
 - Spare capacity occupied by higher layers is pre-empted in the event of a lower layer failure. For example, the capacity occupied by ATM spare resources can be utilized by the SONET layer for SONET restoration.
 - Thus, spare capacity requirements are reduced (“redundant redundancy” is avoided)
 - Applicable only to *Transport-Oriented* approach
 - Planning of higher layer spare resources should be such that lower layer services should carry only *working* higher layer demand. For example, the SONET working demand carries only the working ATM demand in an ATM/SONET network. ATM spare capacity and SONET spare capacity are shared.
 - The main issue is to translate the spare capacity requirements of different services to a common unit. This is facilitated by WDM networks

Degree of Survivability $s(t)$

- $s(t)$ is defined as the ratio of restored demand to affected demand in time t
- Target survivability is s_T in time t_r
- t_R is the restoration time required for full restoration. Thus, $s(t_R) = 1$

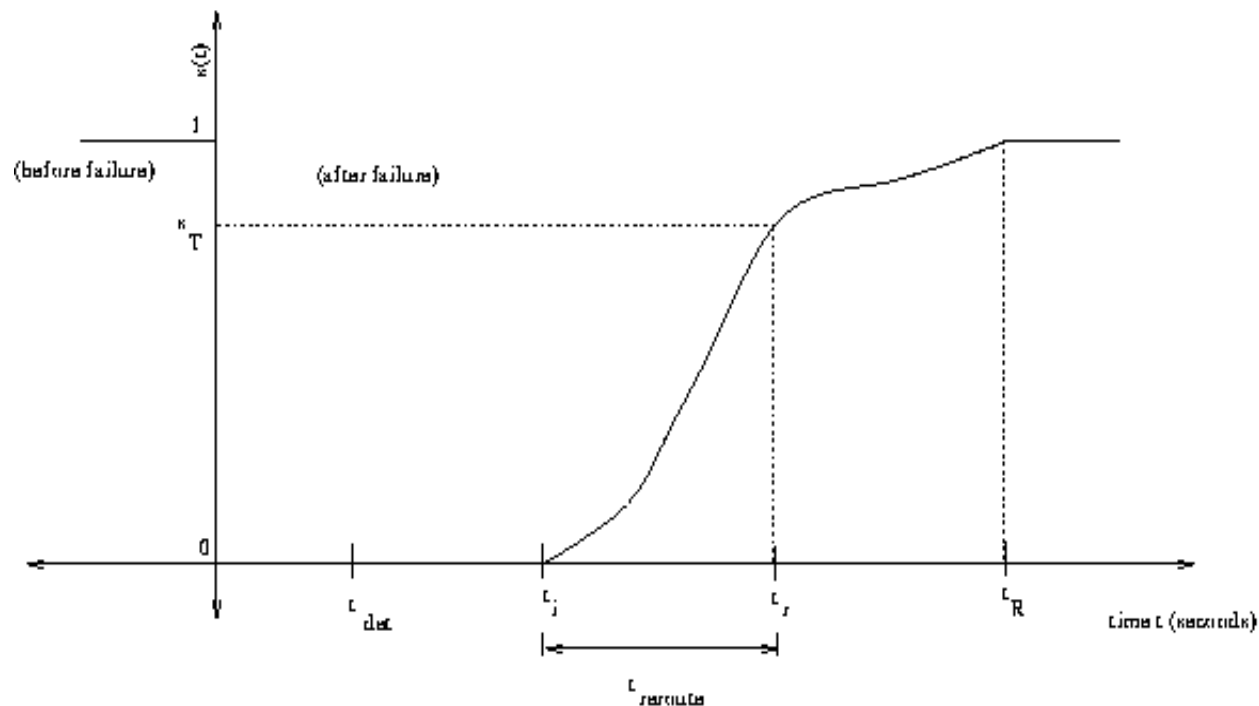

Algorithm for Evaluation of Survivability Approaches

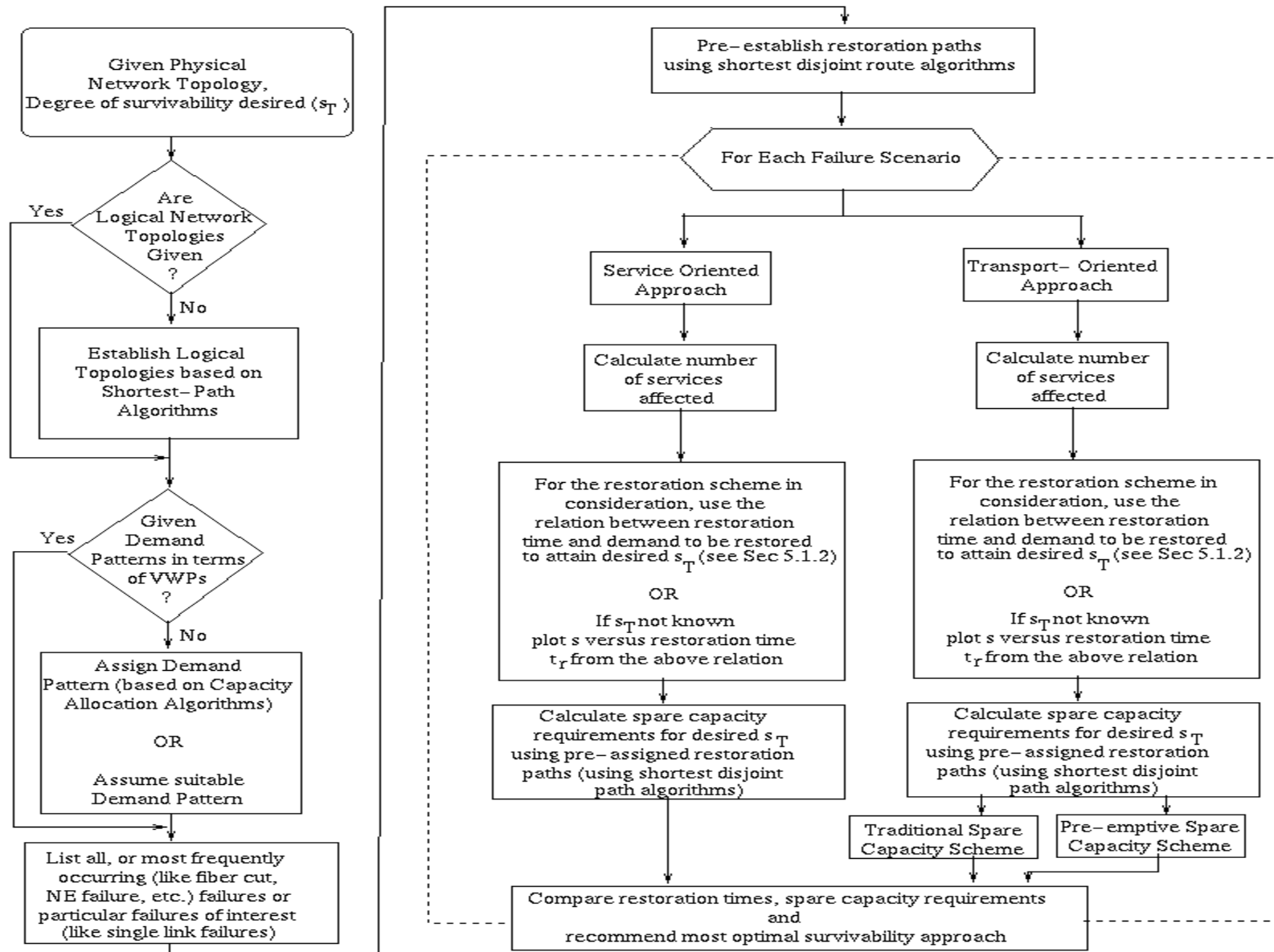

Example Network

Physical Topology

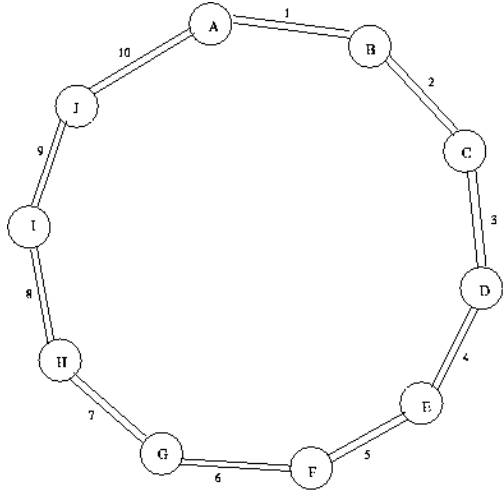

Logical ATM Topology

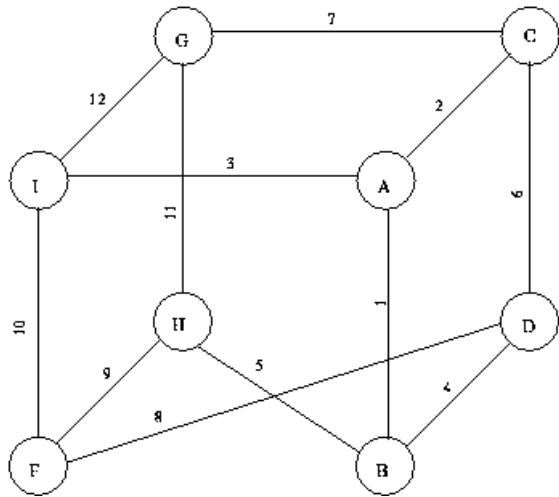

10/13/98

Logical WDM Topology

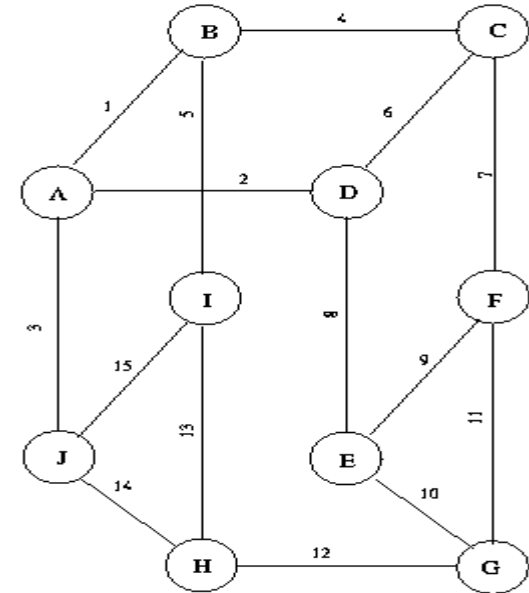

Logical IP Topology

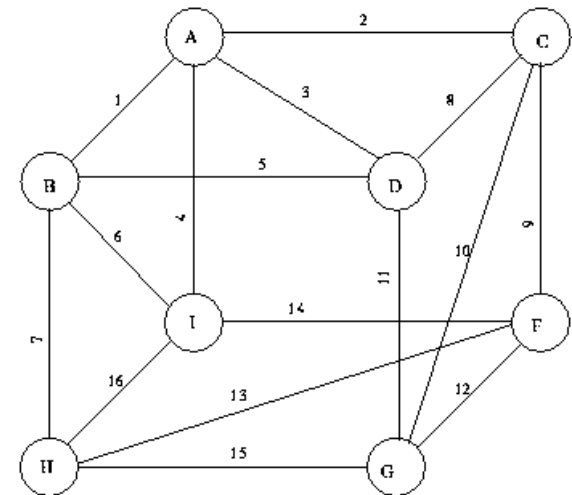

Ananth Nagarajan

23

Example Network (contd.)

- In this analysis, we assume that spare paths are pre-allocated, rather than dynamically allocated in the event of a failure. This assumption is in order to avoid the spare path search time after a failure, to ensure fast recovery from failure.
- We analyze the example network for all possible single link failures (physical links and logical links)
- We assume a unit of demand to be a VWP in order to make the unit bit-rate independent.
- A single service path is assumed to be mapped on to a single VWP. Thus, a single SONET path is mapped to a single VWP, and so is a single ATM VP and a single IP “path”. This assumption is in order to make a comparison between different restoration schemes. A better method of mapping the different service demands to VWPs is for

Results- Comparing restoration at different layers

$s(t)$ versus Restoration time (WDM restoration)

Transport-Oriented Approach, Layered Network

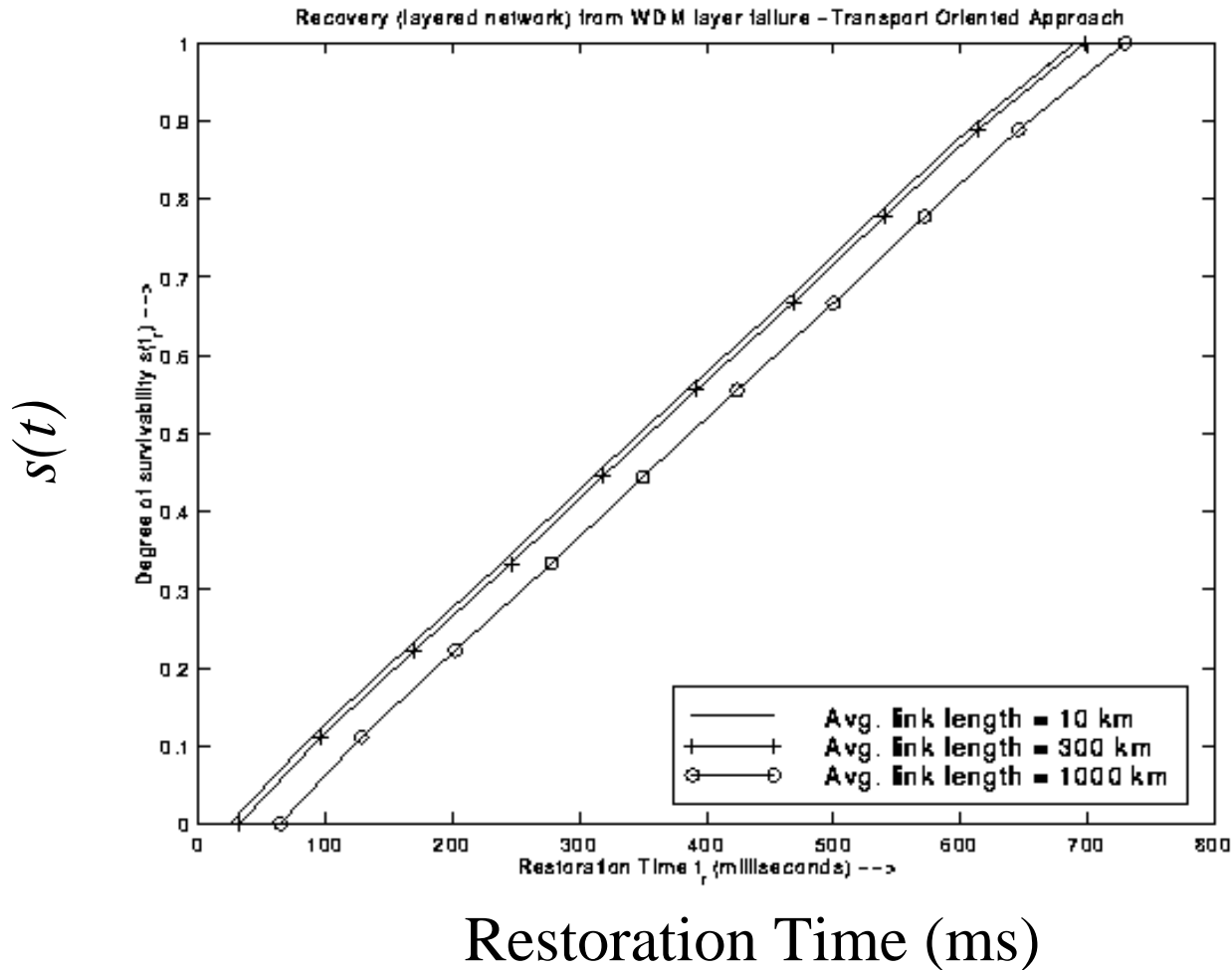

Results- Comparing restoration at different layers

$s(t)$ versus Restoration time (SONET restoration)

Transport-Oriented Approach, Layered Network

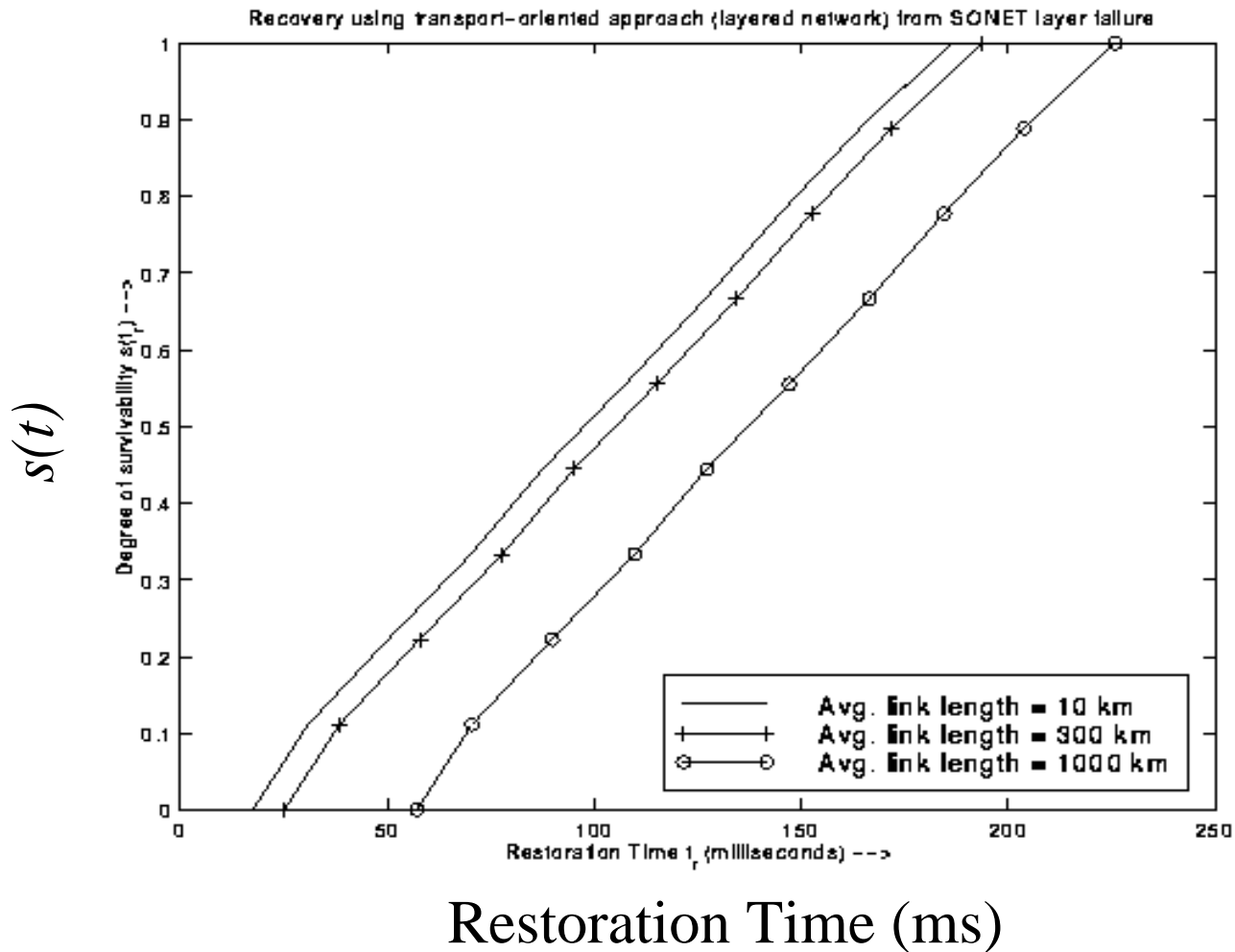

Results- Comparing restoration at different layers

$s(t)$ versus Restoration time (ATM restoration)

Transport-Oriented Approach, Layered Network

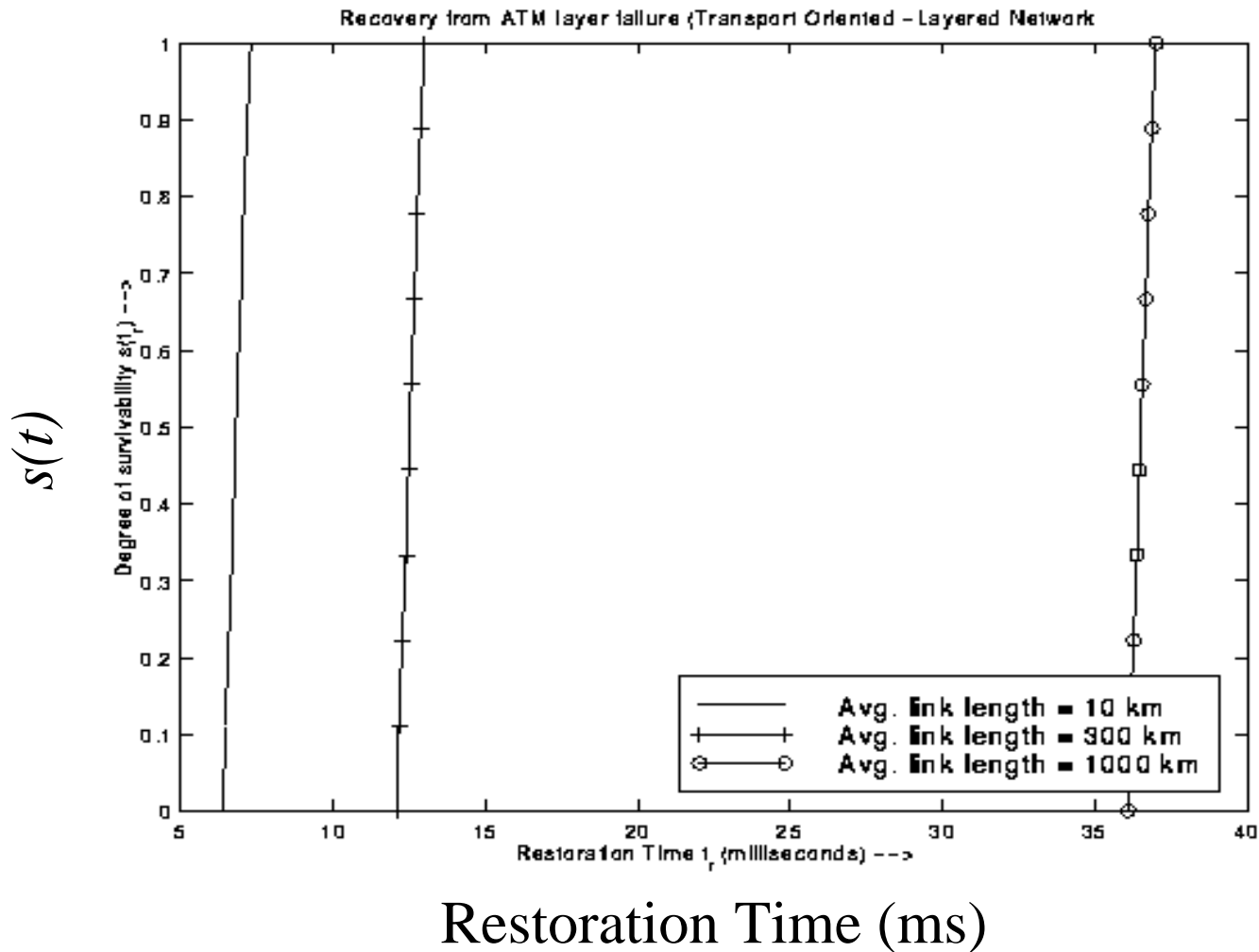

Results- Comparing restoration at different layers

$s(t)$ versus Restoration time (IP restoration)

Transport-Oriented Approach, Layered Network

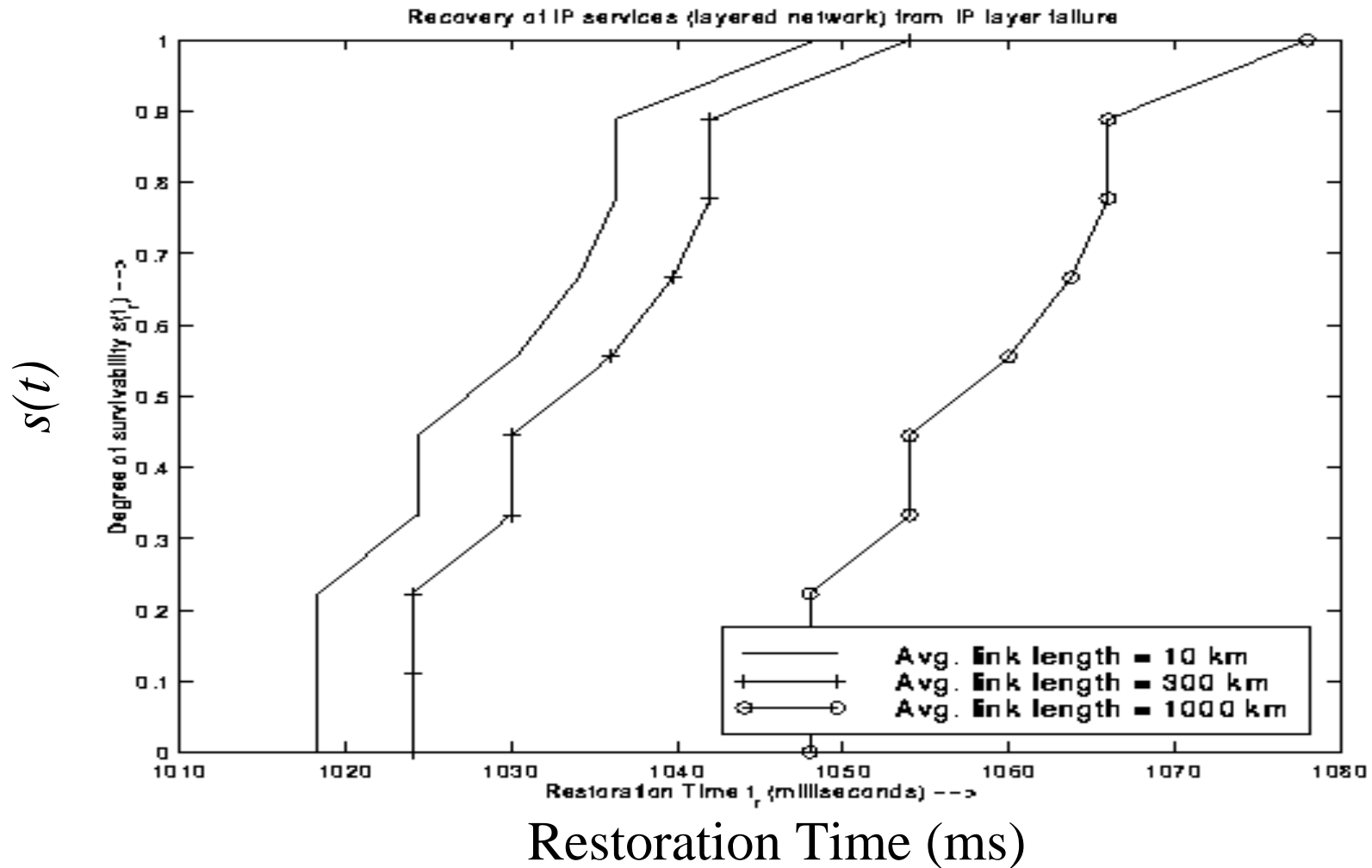

Results -Comparing Service v/s Transport Oriented

$s(t)$ versus Restoration time (SONET restoration)
 Service Oriented Approach, Layered Network, WDM layer failure

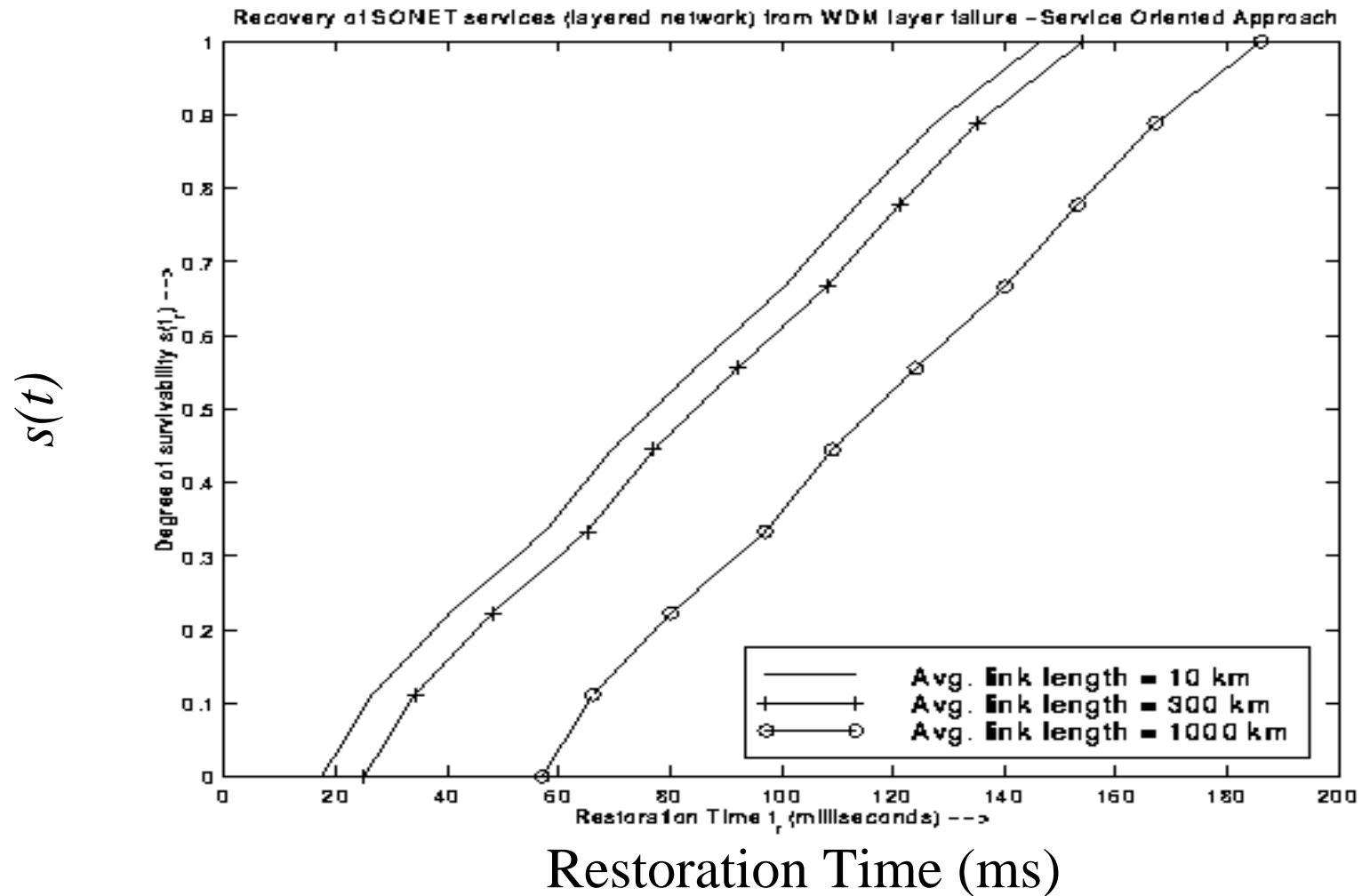

Results -Comparing Service v/s Transport Oriented

$s(t)$ versus Restoration time (SONET restoration)

Transport Oriented Approach, Layered Network, SONET layer failure

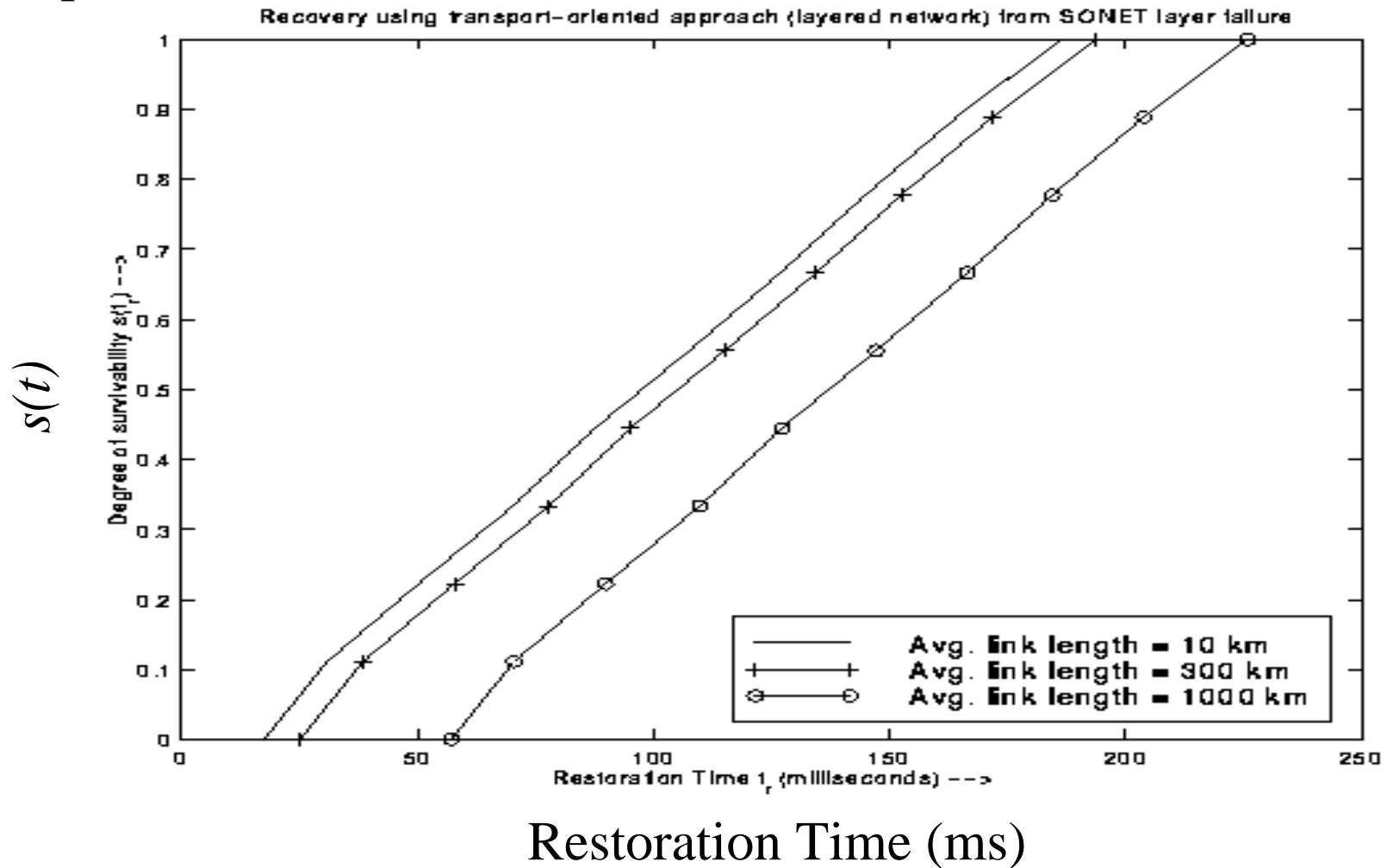

Results -Comparing Transparent v/s Layered Network

$s(t)$ versus Restoration time

(WDM restoration)

Transport Oriented Approach, Layered Network, WDM layer failure

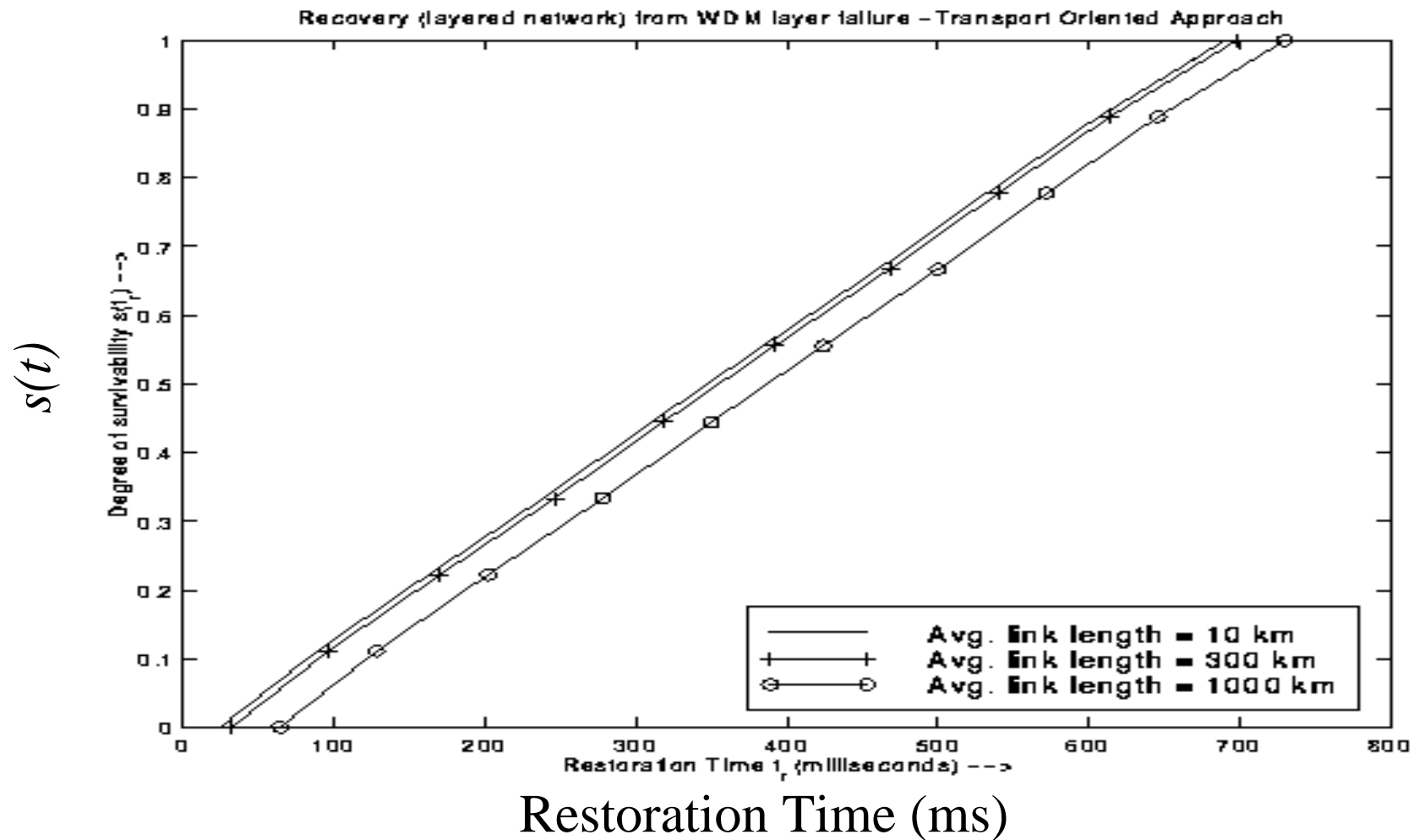

Results -Comparing Transparent v/s Layered Network

$s(t)$ versus Restoration time

(WDM restoration)

Transport Oriented Approach, Transparent Network, WDM layer failure

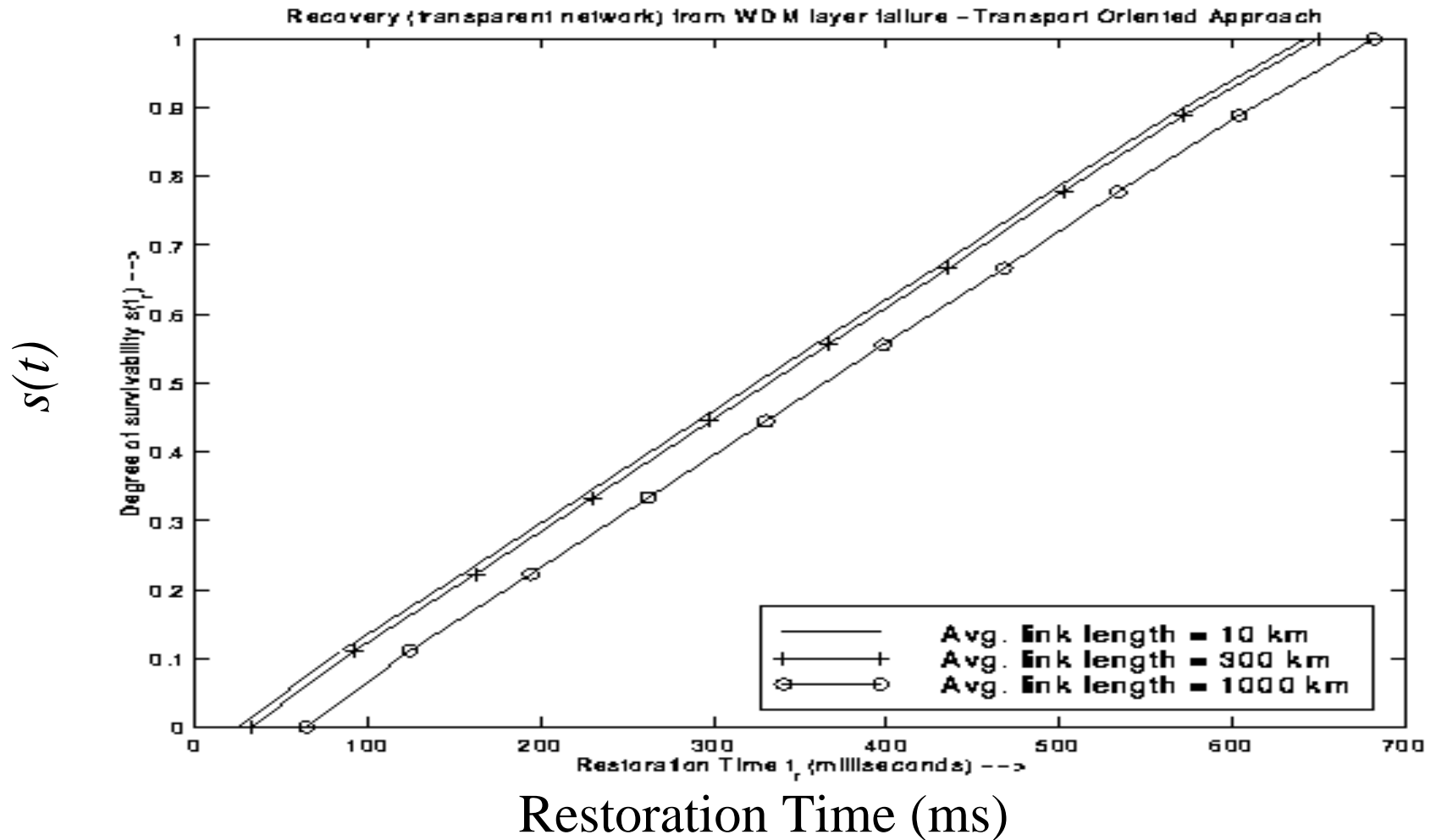

Results

Capacity Requirements

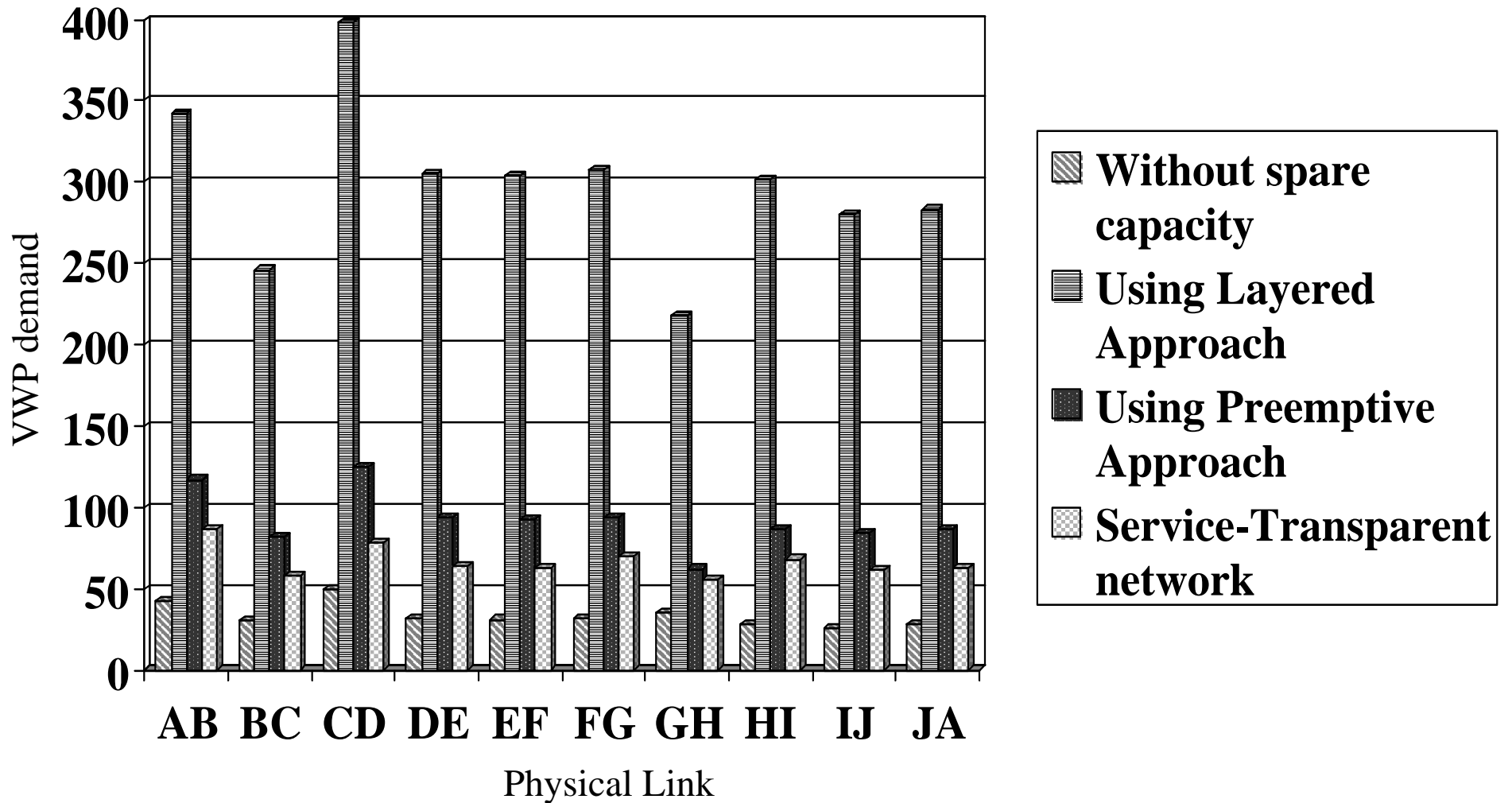

Conclusions and Future Work

- Developed algorithm for comparing different survivability approaches
- Service-oriented scheme involves multiple restorations for single lower link failure, and is good for service-transparent networks
- Transport-oriented scheme allows for single recovery at lower layer, but multiple restoration schemes need to co-exist
- ATM VP restoration is extremely fast
- Pre-emptive spare capacity allocation is very efficient
- Service transparency in optical networks results in capacity savings, minimizing overhead and is recommended for future networks

Future Work

- Better mapping of demand requirements of different services to common unit (VWPs)
- Study multiple link failures (node failures can be considered as multiple link failures)
- Verify performance of algorithm with real life cases and/or simulation
- Consider more complex networks, and verify generality of observations
- Consider cases where services are prioritized, and restoration is load-directed (based on load at a particular time-of-day)