

Traffic Handling and Network Capacity in Multi-Service Networks

Towela P.R. Nyirenda-Jere
Information and Telecommunication
Technology Center
University of Kansas
towela@itc.ukans.edu

Victor S. Frost
Information and Telecommunication
Technology Center
University of Kansas
frost@itc.ukans.edu

Nail Akar
Electrical and Electronics
Engineering Dept.
Bilkent University
akar@ee.bilkent.edu.tr

Abstract— This paper describes the impact of traffic handling mechanisms on network capacity for support of Quality of Service (QoS) in multi-service networks. The choice of which traffic handling strategy to employ requires a methodology that can be used to capture the trade-off between the different schemes and this is the focus of this paper. One key result of this work is that on the basis of capacity requirements, there is no significant difference between class-based traffic handling and per-flow traffic handling.

Keywords— Traffic handling, Quality of Service, Aggregation

I. INTRODUCTION

WHEN the Internet first came into being it was used primarily as a research tool and was designed to deliver uniform service to all users. Over time the Internet has evolved into a commercial entity and has experienced tremendous growth in both the volume of traffic carried as well as diversity in the type of traffic carried. The emergence of applications with diverse throughput, loss and delay requirements requires a network that is capable of supporting different levels of service as opposed to the single best-effort service that was the foundation of the Internet. Quality of Service (QoS) has become the buzzword and umbrella term that captures the essence of this shift in paradigm.

This paper enhances prior research by considering the issue of how network capacity is affected by the particular traffic handling strategy employed for delivery of QoS. There are basically three approaches to traffic handling. The first is best-effort handling in which all flows are queued in the same buffer and share the buffer and link resources. This is the simplest and most prevalent form of traffic handling. The links must be configured with enough capacity to meet the most stringent QoS and the typical approach to maintaining QoS in this situation is to add more capacity to the link - “throwing more bandwidth at the problem”. In the second form of traffic handling, class-based handling, flows are divided into classes based on some criteria, the most obvious one being to group flows with similar QoS requirements. In this way, the QoS needs of a class of flows can be ensured in isolation from other classes. Lastly, there is per-flow handling in which each flow is assigned its own set of resources and thus attains its QoS independent of other flows. This is the best means of ensuring QoS but it is also the most complex to administer. This approach has been referred to as “throwing hardware at the problem” in reference to the increased complexity of network hardware required to implement it.

Given the different traffic-handling models, the question we address is that of determining the equivalence of the different traffic handling mechanisms in terms of their ability to support

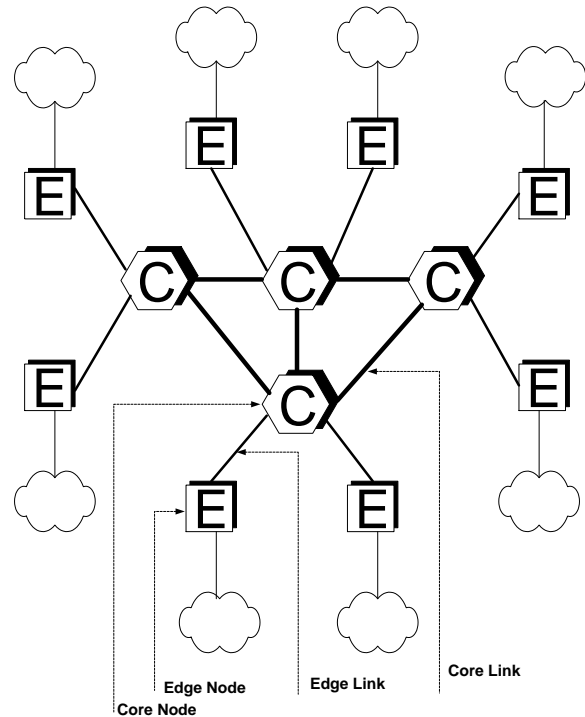

Fig. 1. Network Topology

traffic with varying QoS requirements. Of particular interest is the trade-off between the complexity of traffic handling mechanisms and the network capacity required to support QoS. We begin by discussing the network architecture and analysis in Section II. Numerical results are presented in Section III and we end with conclusions in Section IV.

II. END-TO-END ANALYSIS OF EDGE-CORE NETWORKS

A. Network Architecture

We consider a network architecture that has two distinct hierarchical layers as shown in Fig. 1. For characterization of the traffic sources we used the burstiness constraint model of Cruz [1] in which traffic is characterized by two parameters, a burstiness parameter σ and an average rate parameter ρ . We chose to use this bounded model for the traffic processes so that the results obtained are general and applicable to a variety of situations and do not depend on specific traffic assumptions.

We used four applications voice, video, email and Web data (WWW) grouped into two classes with voice and video belonging to the Real-Time (RT) traffic class and e-mail and WWW traffic belonging to the Non-Real Time (NRT) traffic class. Our choice of these applications was based on the fact that they are

This work was partially supported by a grant from Sprint Technology Planning and Integration

TABLE I
TRAFFIC CLASS PARAMETERS

Traffic Type	Mean Rate (Mbps)	Burstiness (bytes)	Packet Size (bytes)	E2E Delay (sec)
	ρ_k	σ_k	L_k	D_k^{E2E}
Voice	0.064	64	64	0.02
Video	1.5	8000	512	0.05
E-mail	0.128	3072	512	0.5
WWW	1.0	40960	1500	0.5

representative of current network usage and they provide diversity in their attributes and QoS. The quality of service metric we use is the maximum end-to-end queueing delay. Based on the literature we identified parameters for each class as shown in Table I.

We recognize that typically email and WWW traffic are considered to be adaptive applications that do not have strict delay requirements. We thus used delay objectives for WWW that are an order of magnitude higher than those of voice and video to reflect the fact that while WWW traffic may be adaptive, users of WWW applications have certain expectations on delay. The traffic handling schemes that we used are First-in-First-Out (FIFO) for best-effort handling, priority queueing (PQ) and weighted class-based queueing (CBQ) for class-based handling [2] and weighted fair queueing (WFQ) for per-flow handling [2], [3], [4].

B. End-to-End Capacity Analysis

We use results on deterministic end-to-end delay analysis to determine the capacity required to guarantee the delay QoS for each traffic type. The literature on deterministic analysis is vast and we refer the reader to [1], [5], [6], [3], [7], [8], [9] and references therein. The approach used to compare the traffic handling schemes is to calculate the amount of traffic that can be supported in an all-WFQ network and compare this to the capacity required to support the same traffic for various combinations of traffic handling schemes in the edge and core. We use the notation WFQ^* to refer to the reference all-WFQ network. We assume that the end-to-end delay is uniformly distributed among the nodes and the guaranteed bandwidth for each traffic type is the same at each node. Using results in [3], [7], we calculate the guaranteed rate with WFQ*, $g_k^{WFQ^*}$ as:

$$g_k^{WFQ^*} = \max \left\{ \rho_k, \frac{\frac{\sigma_k}{M_T} + L_k}{D_k} \right\} \quad (1)$$

where M_T is the total number of nodes traversed in the network and D_k is the delay per node. The number of sources of each type that can be supported at an edge node using WFQ* is then given by:

$$N_k = \left\lfloor \frac{w_k * C_{edge}}{g_k^{WFQ^*}} \right\rfloor \quad (2)$$

where C_{edge} is the edge link capacity and w_k is the proportion of capacity on the edge link allocated to traffic of type k . For CBQ and PQ with P classes/levels using end-to-end delay analysis results in [1] and [3] the edge capacity is given by:

$$C_{edge}^{CBQ} = \sum_{p=1}^P \sum_{k \in p} \frac{N_k \sigma_k}{D_{class p}} \quad (3)$$

$$C_{edge}^{PQ} = \max_{p=1 \dots P} \left\{ \sum_{j=1}^p \sum_{k \in class j} \frac{N_k \sigma_k}{D_{class p}} + \sum_{j=1}^{p-1} \sum_{k \in class j} N_k \rho_k \right\} \quad (4)$$

where $D_{class p}$ is the delay of class p defined as:

$$D_{class p} = \min_{k \in p} \{D_k\}$$

We will sometimes use the notation $D_{k,p}$ when we wish to refer to the delay of traffic of type k which is assigned to class p . For FIFO we assume that buffers are sized to accommodate the sum of incoming bursts so that the edge capacity is given by:

$$C_{edge}^{FIFO} = \sum_{k=1}^K \frac{N_k \sigma_k}{D_{min}} \quad (5)$$

where D_{min} is given by:

$$D_{min} = \min_k \{D_k\}$$

The capacity required in the core for each scheme has the same general form regardless of the mechanism in the edge. The key differentiating factor is the change in burstiness for a given traffic type induced by the delay in the edge. The burstiness after traversing the edge, σ'_k is given by:

$$\sigma'_k = \sigma_k + \rho_k D_k^{edge} \quad (6)$$

where D_k^{edge} is the delay in the edge which is equal to D_k when the edge uses WFQ, $D_{k,p}$ when the edge uses CBQ or PQ and D_{min} when the edge uses FIFO.

For a WFQ core the minimum required capacity on the link $l(i, j)$ between the core node-pair (i, j) is given by:

$$C_{core(i,j)}^{WFQ} = N_{edge} * \sum_{k=1}^K \sum_{(x,y)} \tau_k^{(x,y)} * N_k^x * g_k \quad (7)$$

where (x, y) represent core nodes with traffic flowing from node x to node y using link $l(i, j)$, $\tau_k^{(x,y)}$ is the fraction of traffic incident at node x destined for node y and N_k^x is the number of

sources of class k whose edge node is attached to core node x . The value of g_k in (7) will depend on the traffic handling in the edge: when the edge uses WFQ, g_k will be the same as g_k^{WFQ} in (1) and when the edge uses any other mechanism, it will be:

$$g_k = \max \left\{ \rho_k, \frac{\frac{\sigma'_k}{M} + L_k}{D_k} \right\} \quad (8)$$

where σ'_k is defined in (6) and M is the number of core nodes. To calculate the core capacity with CBQ, PQ and FIFO, for each link $l(i, j)$ let:

$$\bar{\rho}_k^{(i,j)} = \sum_{(x,y)} \tau_k^{(x,y)} N_k^x \rho_k \quad (9)$$

$$\bar{\sigma}_k^{(i,j)} = \sum_{(x,y)} \tau_k^{(x,y)} N_k^x \sigma_k^{h(x,y)} \quad (10)$$

where $h(x, y)$ is the number of core hops traversed by the traffic before reaching link $l(i, j)$ and $\sigma_k^{h(x,y)}$ is the associated burstiness and the other parameters are as defined for (7). Then the core bandwidth required on link $l(i, j)$ for each scheme is calculated as follows:

$$C_{core(i,j)}^{CBQ} = N_{edge} * \sum_{p=1}^P \sum_{k \in p} \frac{\bar{\sigma}_k^{(i,j)}}{D_{class p}} \quad (11)$$

$$C_{core(i,j)}^{PQ} = N_{edge} * \max_{p=1, \dots, P} \left\{ \sum_{m=1}^p \sum_{k \in class m} \frac{\bar{\sigma}_k^{(i,j)}}{D_{class p}} + \sum_{m=1}^{p-1} \sum_{k \in class m} \bar{\rho}_k^{(i,j)} \right\} \quad (12)$$

$$C_{core(i,j)}^{FIFO} = N_{edge} * \sum_{k=1}^K \frac{\bar{\sigma}_k^{(i,j)}}{D_{min}} \quad (13)$$

III. NUMERICAL RESULTS

Using the procedures outlined in the previous section, the capacity required in the edge and core for all possible combinations of edge-core traffic handling schemes was calculated for different topologies with core nodes ranging from 5 to 20. We used edge links of OC-3 capacity for the reference WFQ network with a load of 95% on each edge link. The total load on the network was fixed by using a total of 60 edge nodes in each topology and assigning an equal number of edge nodes to each core node. Traffic within the core was symmetrically distributed. We will use the specific case of 20 core nodes in a full-mesh topology with a video load of 0.1 to illustrate the results. For this case, each core node supports 3 edge nodes and each core node sends $= 1/19$ of the total incoming traffic to every other core node. For the reference WFQ network, we thus expect the core link bandwidth to be at least $(3 * OC - 3)/19$. The results obtained are presented in the sections that follow.

A. Capacity Requirements with Load Variation

With video load on the edge links fixed at 0.1, we varied the voice load from 0.05 to 0.85 and calculated the edge and core

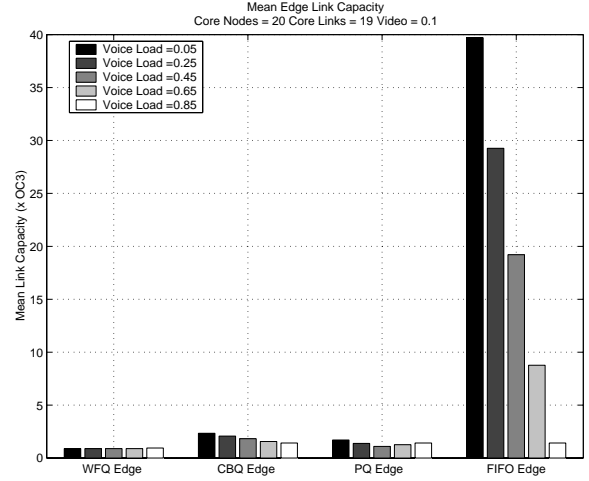

Fig. 2. Mean Edge Capacity

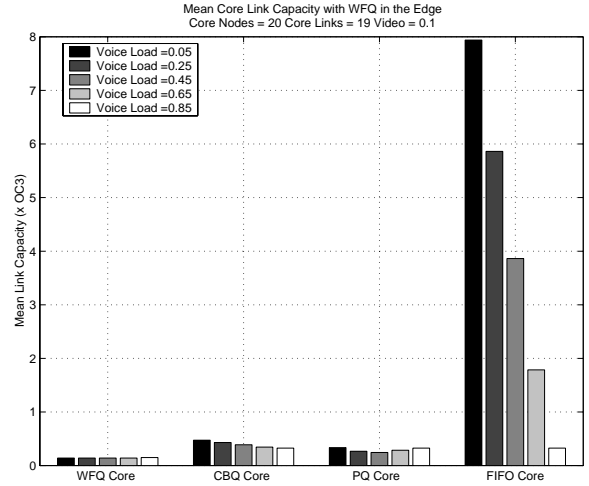

Fig. 3. Mean Core Capacity with WFQ in the Edge

capacity in each case. The e-mail and WWW load were each equal to $0.5 * (0.95 - \text{voice load} - \text{video load})$. Figure 2 shows the mean edge link capacity with WFQ, CBQ, PQ and FIFO edge handling. With CBQ in the edge, the capacity ranges from 2.3 OC-3s when the voice load is 0.05 to 1.4 OC-3s when the voice load is maximum. The PQ edge capacity ranges from 1.7 to 1.4 OC-3s. The capacity required with FIFO in the edge becomes significantly larger than that of the other three schemes as the voice load decreases, ranging from 40 OC-3s when voice load is 0.05 to 1.4 OC-3s when the voice load is at its maximum. The difference in capacity between FIFO and the other schemes is attributed to the fact that with FIFO the delay of all traffic types must be equalized to that of the most stringent delay QoS (voice in this case), and thus more capacity is required to achieve this when the more bursty email and WWW traffic are present. When the voice capacity is at its maximum, email and WWW traffic are zero and the FIFO queue is equivalent to the CBQ and PQ queues.

Figure 3 shows the capacity required for different core schemes when WFQ is used in the edge. We observe that the link capacity of a WFQ core is less than an OC-3, the exact value

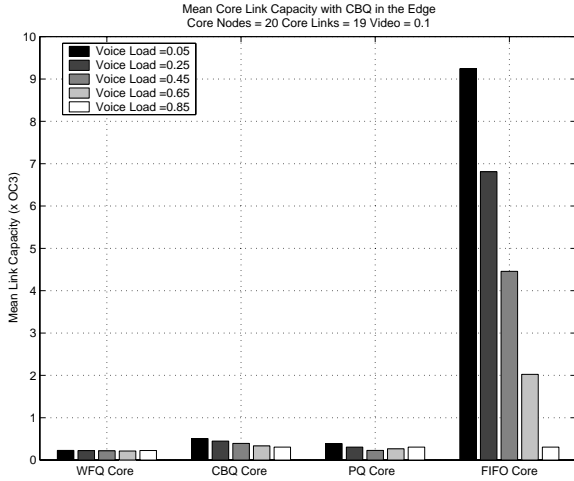

Fig. 4. Mean Core Capacity with CBQ in the Edge

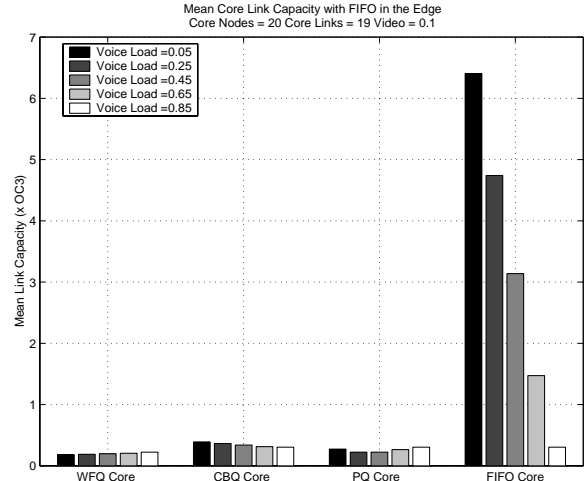

Fig. 5. Mean Core Capacity with FIFO in the Edge

being 0.15 of an OC-3 which agrees with our expectations. With CBQ and PQ in the core, slightly more capacity is needed in the core than with a WFQ core but it is still less than an OC-3. For a FIFO core, the capacity is much higher and ranges from 8 to 0.32 OC-3s. Combining the results of Figure 2 and Figure 3, we see that with WFQ in the edge, the bulk of the network capacity is in the edge for WFQ, CBQ and PQ whereas for FIFO the bulk of the capacity is in the core.

In Fig. 4 we present results for a CBQ edge. We find that for all four traffic handling schemes, the core capacity is of the same order of magnitude as with the previous case of WFQ in the edge. Similar results hold when PQ is used in the edge. With FIFO in the edge the core capacity results are as shown in Fig. 5. The WFQ, CBQ and PQ core capacity are still less than an OC-3. There is however, a slight increase in WFQ core capacity compared to using a non-FIFO edge and a slight decrease in CBQ and PQ capacity. The increase for WFQ is about 0.04 of an OC-3 and is attributed to the increase in burstiness of traffic due to the FIFO edge which results in a larger value of guaranteed bandwidth for each traffic type within the WFQ core. For CBQ and PQ, the capacity decreases because for video, e-mail and WWW, the increase in burstiness with a FIFO edge is less than that with either a WFQ, CBQ or PQ edge since the delay seen by these traffic types in the FIFO edge is less. The FIFO core bandwidth is less than with WFQ, CBQ or PQ in the edge for the same reason. To illustrate the implications of these results in a network-wide sense, we calculated the total network capacity for the 20 core node network in a full-mesh configuration for the specific case of voice load of 0.45 on the edge links. The results are shown in Table II where the capacity is in multiples of OC-3. Looking at the table we see that the all-WFQ network requires the least network capacity while the use of FIFO in either the edge or core requires large amounts of capacity. Using CBQ and PQ with WFQ requires at most 2 times the capacity of the all-WFQ network. The general conclusion to be drawn from these results is that any combination of WFQ, CBQ and PQ in the edge and core will require capacity of the same order of magnitude and on the basis of capacity requirements there is no significant difference between these three schemes.

TABLE II
TRAFFIC HANDLING AND NETWORK CAPACITY IN EQUIVALENT NUMBER
OF OC-3 LINKS

		Core Traffic Handling			
		WFQ	CBQ	PQ	FIFO
Edge Traffic Handling	WFQ	107	201	144	1497
	CBQ	191	256	195	1818
	PQ	146	210	149	1700
	FIFO	1212	1269	1224	2318

B. Effect of Projections on Traffic Growth

According to information on the Cisco website [10], voice traffic is growing at a rate of 10-15% per year while data traffic is growing at a rate of 100-125%. We investigate the impact of projected annual growth of 15% in voice traffic and 100% in WWW traffic over a period of 5 years. We use a network with 20 core nodes and initial edge load of 40% voice, 10% video, 15% email and 15% WWW for illustration.

Figure 6 shows how the edge capacity changes over the 5 year period for different edge traffic handling mechanisms. We find that the WFQ edge capacity increases by a factor of 4 from 0.8 OC-3s to 3.3 OC-3s after the five years. The CBQ bandwidth increases by a factor of 5 while the PQ bandwidth increases by a factor of 6. With FIFO in the edge, there is an almost 10-fold increase in capacity from 17 OC-3s in the first year to 163 OC-3s in the fifth year. These results show that FIFO capacity is the most sensitive to changes in the network load while WFQ is the least. Fig. 7 shows how the core capacity required with FIFO in the edge changes over the five year period. The trend of results is the same as that of the edge capacities with FIFO core bandwidth increasing by a factor of 10 and WFQ by a factor of 4. Results with WFQ in the edge showed the same trend with slight differences in the actual capacity values due to the reasons outlined in Section III-A.

IV. CONCLUSION

We conclude by summarizing the capacity requirements of combinations of edge and core traffic handling mechanisms in

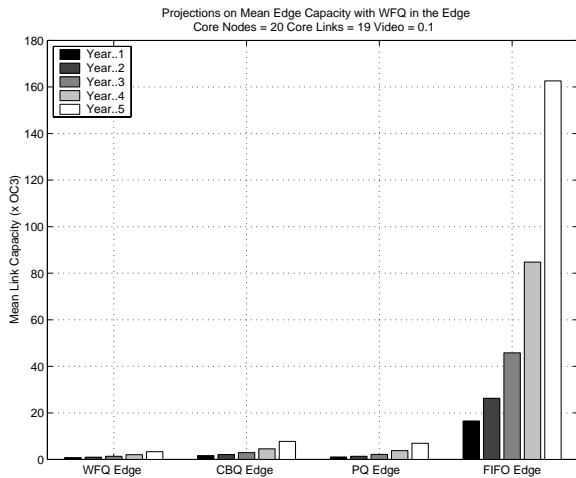

Fig. 6. Projected Mean Edge Capacity

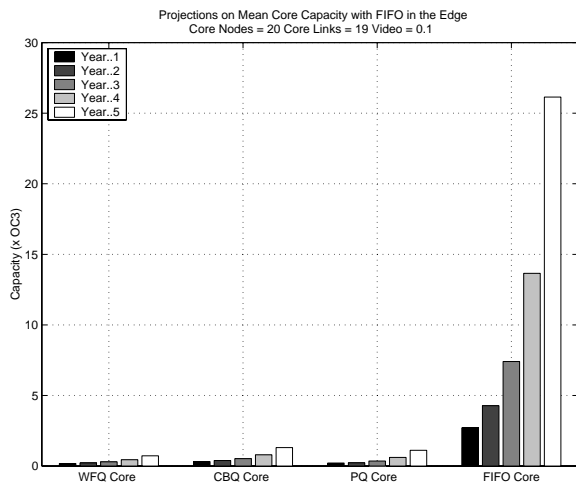

Fig. 7. Projected Mean Core Capacity with FIFO in the Edge

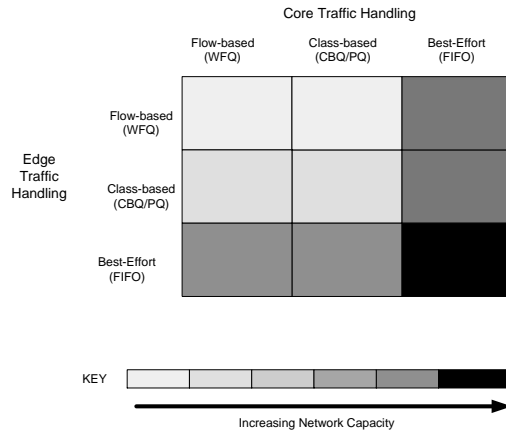

Fig. 8. Capacity Requirements of Edge and Core Traffic Handling Mechanisms

Fig. 8. The diagram which follows from Table II, uses different shades of gray to show how the capacity requirements change depending on the type of traffic handling used in the edge and core portions of the network. For example, we see that with flow-based handling in the edge, class-based handling in the core requires the same order of capacity as flow-based handling in the core. Given that one objective is to simplify network management, the use of flow-based handling in the core portion of the network may not be practical and the choice between which combination of traffic handling mechanisms to use will depend in part on the availability of bandwidth in the edge and core portions of the network. With significant amounts of bandwidth in the core, then either class-based or flow-based handling can be used in the edge with best-effort handling in the core portion of the network. If some complexity in the core can be tolerated then with moderate capacity, flow-based or class-based handling can be used in the edge with class-based handling in the core.

REFERENCES

[1] Cruz R.L., *A Calculus for Network Delay, Part I: Network Elements in Isolation*, IEEE Transactions on Information Theory, Vol 37, no. 1, Jan, 1991.
 [2] Floyd S., V. Jacobson, *Link-sharing and Resource Manage-*

ment Models for Packet Networks, IEEE/ACM Trans. On Networking, vol 3, no. 4, Aug. 1995.
 [3] Parekh A., R. Gallager, *A Generalized Processor Sharing Approach to Flow Control in Integrated Services Networks: The Single Node Case*, IEEE/ACM Transactions on Networking, Vol. 1, no. 3, June 1993.
 [4] Zhang H., *Service Disciplines for Guranteed Performance Service in Packet Switching Networks*, Proc. IEEE, vol. 83, no. 10, Oct. 1995.
 [5] Cruz R.L., *A Calculus for Network Delay, Part II : Network Analysis*, IEEE Transactions on Information Theory, Vol 37, no. 1, Jan, 1991.
 [6] Le Boudec J., *Network Calculus Made Easy*, Tech. Report EPFL-DI 96/218, <http://lrcwww.epfl.ch/PSfiles/d4paper.ps>, Dec. 1996
 [7] Parekh A., R. Gallager, *A Generalized Processor Sharing Approach to Flow Control in Integrated Services Networks: The Multiple Node Case*, IEEE/ACM Transactions on Networking, Vol. 1, no. 3, June 1993.
 [8] Schwartz M., *Broadband Integrated Networks*, Prentice Hall, 1996.
 [9] Stiliadis D., A. Varama, *Latency-Rate Servers: A General Model for Analysis of Traffic Scheduling Algorithms*, IEEE/ACM Trans. on Networking vol. 6, no. 5, Oct. 1998, p.611-624.
 [10] Cisco Government Affairs Website, www.cisco.com/warp/public/779/govtaffs